

# **Attachment 13**

---

Traffic Assessment

Neilsens Quarry - North Bromelton

# TRAFFIC AND PAVEMENT IMPACT ASSESSMENT REPORT

Prepared for: The Neilsen Group

January 2023

**File Ref:**  
documents / 20230113\_10551\_TPIA

## Project / Report Details

<b>Document Title:</b>	Traffic and Pavement Impact Assessment Report
<b>Principal Author:</b>	Jamie Murray
<b>Client:</b>	The Neilsen Group
<b>Ref. No.</b>	20230113_10551_TPIA

## Document Status

<b>Issue</b>	<b>Description</b>	<b>Date</b>	<b>Author</b>	<b>Reviewer</b>
1	Traffic Report	13 January 2023	Jamie Murray	Bryce Trevilyan

## Distribution Record

<b>Recipient</b>	<b>Distribution Method</b>
Groundwork Plus	1e

**Traffic & Transport Plus** ABN: 54 619 700 239

**Queensland**  
6 Mayneview Street, Milton Qld 4064  
PO Box 1779, Milton BC, Qld 4064  
P: +61 7 3871 0411

E: enquiry@ttplus.com.au

### Copyright ©

*These materials or parts of them may not be reproduced in any form, by any method, for any purpose except with written permission from Traffic & Transport Plus.*

# Table of Contents

<b>1</b>	<b>Introduction</b>	<b>5</b>
<b>2</b>	<b>Subject Site</b>	<b>6</b>
2.1	Site Location and Site Layout Plan	6
2.2	Existing Road Network	6
<b>3</b>	<b>The Transport Routes</b>	<b>7</b>
<b>4</b>	<b>Traffic Volumes</b>	<b>8</b>
4.1	2022 Traffic Volumes	8
4.2	Base Traffic Volumes	8
4.3	Trip Generating Characteristics	9
4.4	Design Traffic Volumes	11
<b>5</b>	<b>Traffic Impact Assessment</b>	<b>12</b>
5.1	Intersection Performance of the Sandy Creek Road Access	12
5.2	Intersection Performance of the Beaudesert-Boonah Road / Sandy Creek Road Intersection	13
<b>6</b>	<b>Safety Assessment</b>	<b>14</b>
6.1	Sight Distances	14
6.2	Turn Lane Treatments	15
6.2.1	Turn Lane Assessment of the Sandy Creek Road site access	17
6.3	Crash Statistics	18
6.4	Conclusions in relation to Safety	18
<b>7</b>	<b>Pavement Impact Assessment on Sandy Creek Road</b>	<b>19</b>
7.1	Monetary Contributions for pavement impacts on Sandy Creek Road	19
7.2	Overlay Works on Sandy Creek Road	19
<b>8</b>	<b>Pavement Contributions for Impacts on State-controlled Roads</b>	<b>24</b>
8.1	Assessment Parameters	24
8.2	Project Operational Parameters	24
8.3	Pavement Contribution	24
<b>9</b>	<b>Summary of Findings</b>	<b>25</b>

# Table of Contents

## TABLES

Table 1: Existing Road Hierarchy.....	6
Table 2: 2034 Operational Characteristics of the Sandy Creek Road Site Access.....	12
Table 3: 2034 Operational Characteristics of the Beaudesert-Boonah Road / Sandy Creek Road Intersection.....	13
Table 4: Review of Sight Distances at the Sandy Creek Road Site Access .....	14
Table 5: Design Traffic Volume Parameters – Sandy Creek Road Site Access .....	17
Table 6: Existing Pavement Parameters.....	20
Table 7: Base ESA Estimates – Sandy Creek Road.....	22
Table 8: Development ESA Calculations and Adopted Parameters .....	22
Table 9: Design ESAs Including the Expanded Quarry.....	23
Table 10: Appropriate Pavement Contribution of the Neilsens Bromelton Quarry (for production from 1tpa to 800,000tpa).....	24

## FIGURES

Figure 1: Subject Site.....	6
Figure 2: Transport Routes .....	7
Figure 3: Locations of Traffic Surveys.....	8
Figure 4: Locations of DTMR Traffic Census Stations .....	9
Figure 5: Modelled Existing Configuration of the Sandy Creek Road Site Access .....	12
Figure 6: Modelled Existing Configuration of the Beaudesert-Boonah Road / Sandy Creek Road Intersection .....	13
Figure 7: Contour Map and Sight Distances .....	15
Figure 8: Warrants for Turn Lane Treatments.....	16
Figure 9: Calculation of Major Road Traffic Volumes.....	16
Figure 10: Warrants for Turn Lane Treatments – Sandy Creek Road Site Access.....	17
Figure 11: Rural Basic Left (BAL) Turn Treatment.....	18
Figure 12: Locations of the Boreholes – Sandy Creek Road Soil Testing “Subject Site” reference added by TTPlus.....	20

## APPENDICES

Appendix A	Site Layout Plan
Appendix B	Traffic Volume Diagrams
Appendix C	Results of SIDRA Analyses
Appendix D	Results of Traffic Surveys
Appendix E	Results of Soil Testing on Sandy Creek Road
Appendix F	Results of Pavement Contribution Assessment for Impacts on State-controlled Roads

# 1 Introduction

---

Traffic & Transport Plus (**TTPlus**) has been commissioned by The Neilsen Group (**Neilsens**) to prepare a traffic and pavement impact assessment report as part of a development application for the proposed expansion of the eastern quarry footprint of the Neilsens Bromelton Quarry located at 291 Sandy Creek Road, Bromelton, properly described as Lot 1 on RP98576 (the **Subject Site**).

The Neilsens Bromelton Quarry is currently operating pursuant to Consent Order for Material Change of Use – Development Permit for Extractive Industry (ref: 3448 of 2003) granted on 23 June 2004 (**Consent Order**), which allows for extraction of 400,000 tonnes per annum (**tpa**) of material in stages. Neilsens also holds an Environmental Authority for Environmentally Relevant Activities 16(2)(b) and 16(3)(b) (**EA**) which allows for the extraction and screening of between 100,000 and 1,000,000tpa.

The subject application for the Neilsens Bromelton Quarry seeks to alter the quarry footprint and to increase the annual extraction volumes from 400,000 to 800,000tpa (**expanded quarry**). No changes to the other traffic-related aspects of the operation are proposed (eg. hours of operation, site access, staff numbers and haulage routes etc).

It is understood that due to changes in the planning approval framework, the current Court Order cannot be amended to include the proposed changes in scale and intensity of the operation. As such, the current development application is intended to result in a new, fresh development approval, the conditions of which will replace the Consent Order.

It is understood that under the current Court Order, there is approximately 3-4 years of resource remaining within the approved Stage 4 footprint. The alterations to the quarry footprint will achieve an additional 4-5 years of resource. Based on this, the Neilsens Bromelton Quarry is expected to operate up until around 2030 (2023 + 7) to 2032 (2023 + 9) (depending on market demands). For the purpose of this traffic and pavement impact assessment, it is assumed that the expanded quarry would start operation in 2024 and the design year for the expanded quarry has conservatively been assumed to be 2034.

It is noted that the existing Barro Bromelton Quarry (permitted to produce up to 1.5 million tpa by road) is located directly adjacent to the south of Neilsens Bromelton Quarry.

An assessment of the operational impacts of the expanded quarry on the external road network has been undertaken using SIDRA 9 intersection analysis software (**SIDRA**). As part of the SIDRA analysis, the assessment philosophy has included the concept of a “peak hour factor” (more information provided in Section 4.3), to provide additional surety that suitable infrastructure is in place at commencement of, and through the life of the expanded quarry, to cater for the likely ‘worst-case-scenario’ peak operating conditions of the expanded quarry. This methodology is considered to be a suitably conservative approach to the analysis.

This report addresses the following traffic-related issues:

- The transport routes;
- Additional trips (both heavy and light vehicles) associated with the expanded quarry;
- Traffic impacts associated with the expanded quarry on the adjacent external road network;
- Safety issues on the adjacent external road network in consideration of the additional traffic generated by the expanded quarry, and
- Pavement impacts / contributions associated with the expanded quarry.

A summary of the findings is provided in Section 9 of this report.

## 2 Subject Site

### 2.1 Site Location and Site Layout Plan

The Subject Site is located at 291 Sandy Creek Road, Bromelton. The existing site access on Sandy Creek Road is approximately 2.87km south (measured along Sandy Creek Road) of the Beaudesert-Boonah Road / Sandy Creek Road intersection. Figure 1 illustrates the location of the site access relative to Beaudesert-Boonah Road and Sandy Creek Road.

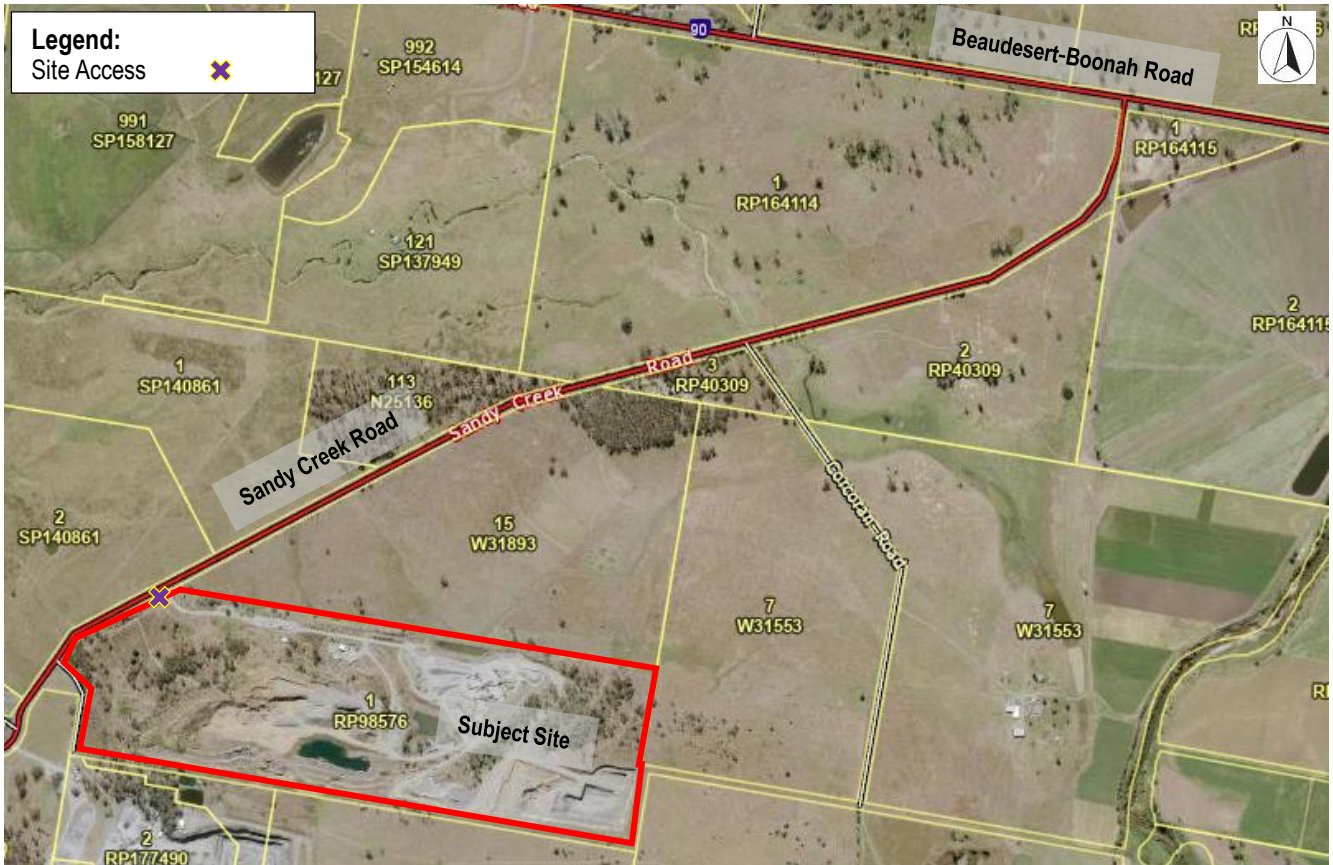

**Figure 1: Subject Site**

Source: QLD Globe

The site layout plan for the expanded quarry is included as Appendix A.

### 2.2 Existing Road Network

The hierarchical classification and characteristics of the roads in the vicinity of the Subject Site are described in Table 1 below.

**Table 1: Existing Road Hierarchy**

Road	Description	Road hierarchy	Authority	Speed Limit
Beaudesert-Boonah Road	2 lane sealed carriageway	State-controlled road (SCR)	The Department of Transport and Main Roads (DTMR)	100km/h*
Sandy Creek Road	2 lane sealed carriageway	Collector	Scenic Rim Regional Council (Council)	100km/h*

\*Speed limits have been confirmed by the independent traffic survey company engaged to undertake the traffic surveys completed in conjunction with this project.



### 3 The Transport Routes

The existing transport routes related to the Subject Site are Sandy Creek Road (north), Beaudesert-Boonah Road (east & west), Beaudesert Bypass Road and Mount Lindesay Highway (north & south). It is noted that the Beaudesert Bypass Road was constructed and opened to traffic on 20 September 2017, which naturally forms an additional link in the haulage road network that was not envisaged at the time of the existing approval. The subject application would seek to formalise / ratify its logical (and intended) use.

Mount Lindesay Highway, Beaudesert Bypass Road and Beaudesert-Boonah Road are SCRs. The existing transport routes are illustrated by the blue lines on Figure 2.

These existing transport routes are proposed to be continued to be utilised for haulage related to the expanded quarry.

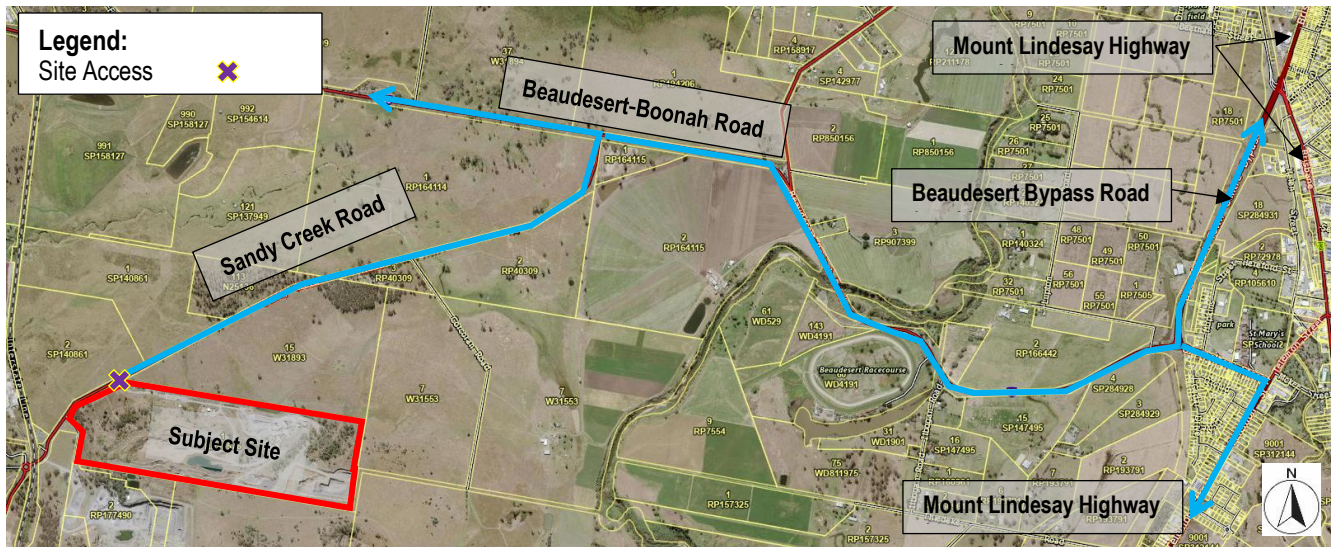

**Figure 2: Transport Routes**

Source: QLD Globe [annotations and road names added by TTPlus]

The haulage trucks used by the existing quarry and intended to be used by the expanded quarry are a mixture of truck & dogs, single body trucks and B-doubles. No road trains are proposed to be used by Neilsens Bromelton Quarry.



## 4 Traffic Volumes

### 4.1 2022 Traffic Volumes

To assist in the preparation of this assessment, determination of the existing background traffic volumes is required. Traffic surveys were undertaken at the Beaudesert-Boonah Road / Sandy Creek Road intersection and the Neilsens Bromelton Quarry site access on Sandy Creek Road on Wednesday 20 April 2022 from 6:30am to 9:30am and from 2:30pm to 6:00pm.

The locations of the traffic surveys are illustrated on Figure 3. The detailed results of the traffic surveys are included in Appendix D.

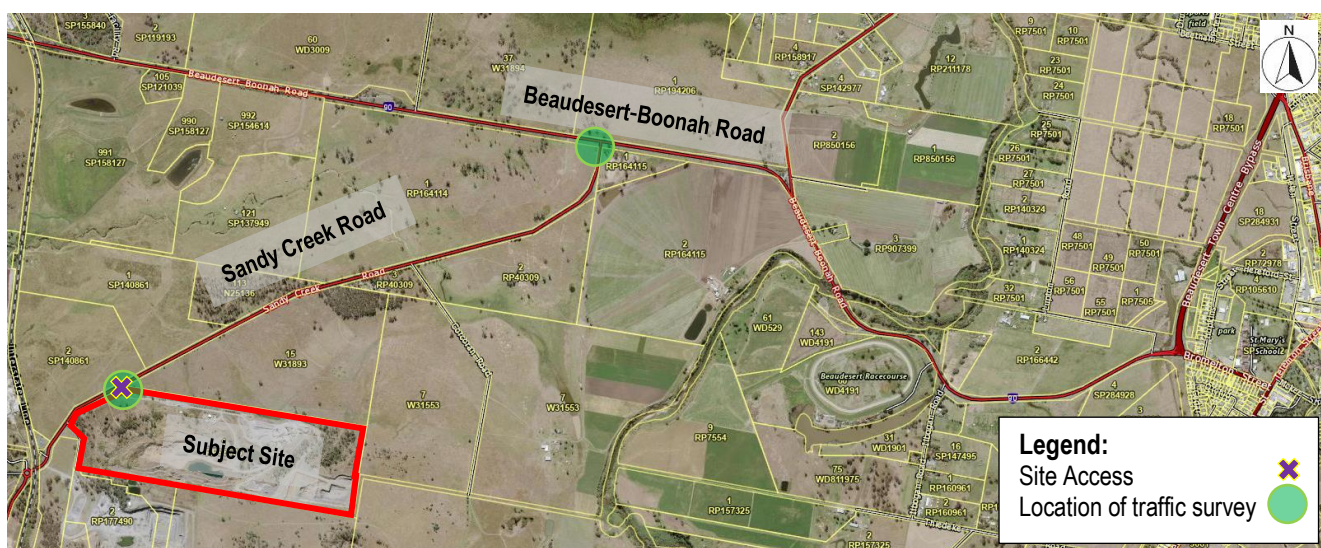

**Figure 3: Locations of Traffic Surveys**

Source: QLD Globe [annotations added by TTPlus]

The observed AM and PM peak hour periods identified were as follows:

- Beaudesert-Boonah Road / Sandy Creek Road intersection:
  - 8:00am to 9:00am and 3:00pm to 4:00pm
- Neilsens Bromelton Quarry site access:
  - 8:15am to 9:15am and 3:45pm to 4:45pm
- Sandy Creek Road roundabout:
  - 8:15am to 9:15am and 3:45pm to 4:45pm

Figure B1 within Appendix B illustrates the 2022 Observed AM and PM peak hour traffic volumes.

### 4.2 Base Traffic Volumes

Background traffic data was sourced from the DTMR traffic census stations along the Mount Lindesay Highway and Beaudesert-Boonah Road to assist in forecasting an appropriate background traffic growth rate. The annual average daily traffic (AADT) and growth rates of the nearby SCRs are listed below:

- Beaudesert-Boonah Road (station no. 10012), west of Sandy Creek Road:
  - From 3,075 vehicles per day (vpd) in 2010 to 3,469vpd in 2021
  - Growth rate: 1.1% p.a. (compound)
- Mount Lindesay Highway (Beaudesert Bypass Road) (station no. 13041), north of Beaudesert-Boonah Road:
  - From 2,442vpd in 2018 to 2,129vpd in 2021
  - Growth rate: -4.5% p.a. (compound)
- Mount Lindesay Highway (station no. 13040), north of Beaudesert-Boonah Road:
  - From 13,156vpd in 2018 to 12,243vpd in 2021
  - Growth rate: -2.3% p.a. (compound)
- Mount Lindesay Highway (station no. 11753), south of Beaudesert-Boonah Road:
  - From 4,702vpd in 2010 to 6,096vpd in 2021
  - Growth rate: 2.4% p.a. (compound)

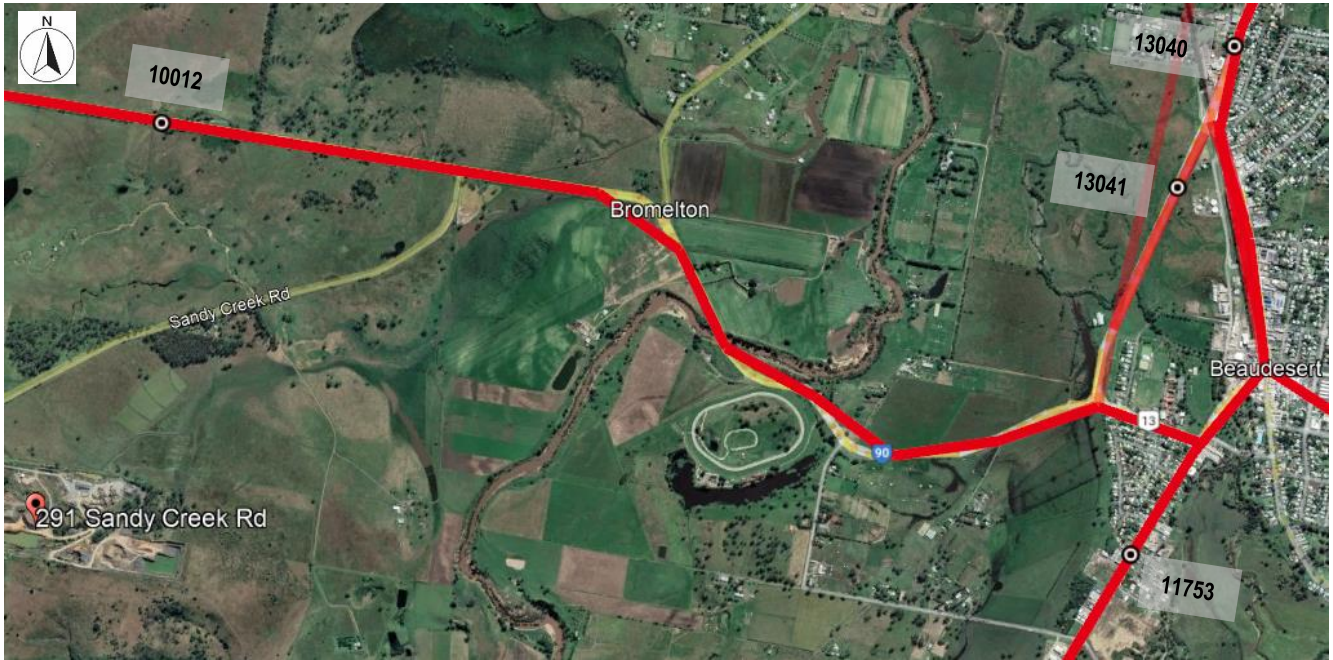

**Figure 4: Locations of DTMR Traffic Census Stations**

Whilst future traffic growth can only be estimated, for the purpose of this assessment, a traffic growth rate of 2.0% p.a. (compound) has been adopted to estimate future background traffic volumes on the external road network proximate to the Subject Site. This is considered to be an appropriate assumption.

Figures B2 and B3 within Appendix B illustrate the 2024 and 2034 base traffic volumes (with the existing quarry) during the AM and PM peak hour periods.

### 4.3 Trip Generating Characteristics

TTPlus has been advised that the operational hours of the haulage activities of the existing quarry (400,000tpa) are 6:00am to 6:00pm (12 hours) Monday to Friday (5 days) and 7:00am to 5:00pm (10 hours) on Saturdays. The proposed permitted operational hours of the expanded quarry (800,000tpa) will remain the same.

#### Truck trips associated with the expanded quarry

In order to ensure sufficient infrastructure is in place to cater for the 'worst-case' operational scenario, the analysis has conservatively assumed that the expanded quarry would be likely to generate more than the typical hourly traffic volumes during the peak hour periods by introducing the concept of a "peak hour factor". The peak hour factor is the ratio of the absolute peak operating conditions to the average operating conditions of the critical year as modelled for the expanded quarry. This represents what is considered to be the 'worst-case' peak operational scenario (ie. the appropriate design case) and accounts for all aspects of variations expected throughout each day and the year for the haulage activities.

TTPlus has been advised that the annual production rate of the existing quarry in 2020/2021 was slightly more than 350,000tpa (but less than 400,000tpa). For the purpose of this assessment, it is conservatively assumed that the annual production rate of the existing quarry in 2021/2022 was approximately 350,000tpa. The trips generated by the existing quarry (350,000tpa) would already be included in the traffic survey undertaken in April 2022.

The estimated additional trip generation associated with the expanded quarry (800,000tpa) is outlined below.

- Maximum annual production rate: 450,000tpa (ie. increase from 350,000tpa to 800,000tpa);
- Operational days per year: 300 days\*;
- Operational hours:  $[(12 \times 5 + 10 \times 1) / 6] = 11.67$  hours (6:00am to 6:00pm (from Monday to Friday) and 7:00am to 5:00pm (Saturday));
- Fleet mix: 13t payload trucks (9%), 36t payload truck & dogs (86%) and 40t payload B-doubles (5%);
- Average mass of material per vehicle\*\*: 34.13 tonnes per vehicle;
- Peak hour factor\*\*\*: 3;
- Peak hour traffic volume (IN):  $[450,000 \div 300 \div 11.67 \div 34.13 \times 3] = 11.3 \rightarrow 11\text{vph}$ , and
- Peak hour traffic volume (OUT): 11vph (assumed same as IN traffic volumes).

\*Operational days based on 50 weeks x 6 days.

\*\*TTPlus has been advised that 13.0t payload single body trucks (9%), 36.0t payload truck & dogs (86%) and 40.0t payload B-doubles (5%) will be used. The average mass of material per vehicle of the assumed fleet has been calculated by factoring the mass of material able to be transported by these vehicles and considering the relative proportions of them within the vehicle fleet. Therefore, the average mass of material per vehicle of the assumed fleet =  $[13.0t \times 0.09 + 36.0t \times 0.86 + 40.0t \times 0.05] = 34.13$  tonnes per vehicle.

\*\*\*The peak hour factor is the ratio of the absolute peak operating conditions to the average operating conditions of the critical year as modelled for the expanded quarry. This represents what is considered to be the 'worst-case' peak operational scenario and accounts for all aspects of variations expected throughout each day and the year.

These resultant volume forecasts are appropriately conservative for the purpose of this assessment. It is also conservatively assumed within the modelling that the development peak and the on-road peak are coincident.

This 'worst-case' operational scenario is a design consideration only and is unlikely to occur as part of the actual day to day operations. The analysis methodology used is intended to ensure that sufficient infrastructure is provided in the vicinity of the site and to enable the safe and efficient operation of the surrounding road network.

### Car Trips

TTPlus has been advised that there are 15 staff working at the existing quarry site (excluding truck drivers) and that the number of staff would remain unchanged for the expanded quarry. Staff trips of the existing quarry would have been included in the traffic surveys undertaken in April 2022.

Visitors would generally not arrive / leave the site during the AM and PM haulage peak periods; notwithstanding this, the conservative allowances of an additional 10vph (7vph IN + 3vph OUT) during the AM peak hour period and an additional 10vph (3vph IN + 7vph OUT) during the PM peak hour period have been included in the analysis. This is a conservatively high allowance for additional staff / visitor car trips coinciding with the haulage and on-road peak periods. Additionally, it is noted that it has also been conservatively assumed that all peaks coincide.

The allowance for additional trips generated by visitors (car trips) is in addition to the modelled additional trips generated by the haulage activities (truck trips) of the expanded quarry discussed above. The travel routes of additional visitors are not known at this stage, however, for the purpose of this assessment, it has been assumed that all the staff would travel to / from the site from / to (or via) Beaudesert town centre.

### Trip Distribution

TTPlus has been advised that almost all deliveries turn right (north) from the Subject Site and drive along Sandy Creek Road to Beaudesert-Boonah Road where approximately 90% turn right and head towards Beaudesert. Based on this information the following trip distribution has been adopted:

- Beaudesert-Boonah Road (west): 10%;
- Mount Lindesay Highway (north) via Beaudesert-Boonah Road (east): 82%, and
- Mount Lindesay Highway (south) via Beaudesert-Boonah Road (east): 8%.

It is likely that some material would be delivered along the haul route. In the absence of more detailed information, the analysis approach adopted herein is considered to be appropriate. The trips estimated to be generated by the expanded quarry are illustrated on Figure B4 within Appendix B.

#### 4.4 Design Traffic Volumes

For the reasons outlined earlier in this report, the resultant traffic volume forecasts are considered to be appropriately conservative for the purpose of this assessment.

The 2024 design peak hour traffic volumes [Figure B5] = 2024 base peak hour traffic volumes [Figure B2] + Trip generation associated with the expanded quarry [Figure B4]

The 2034 design peak hour traffic volumes [Figure B6] = 2034 base peak hour traffic volumes [Figure B3] + Trip generation associated with the expanded quarry [Figure B4]

## 5 Traffic Impact Assessment

Future operation of the Sandy Creek Road site access and the Beaudesert-Boonah Road / Sandy Creek Road intersection have been assessed and discussed below. The detailed results of the SIDRA analyses for these key intersections are provided as Appendix C.

### 5.1 Intersection Performance of the Sandy Creek Road Access

The modelled existing configuration of the Sandy Creek Road site access intersection, as assessed using SIDRA, is shown as Figure 5.

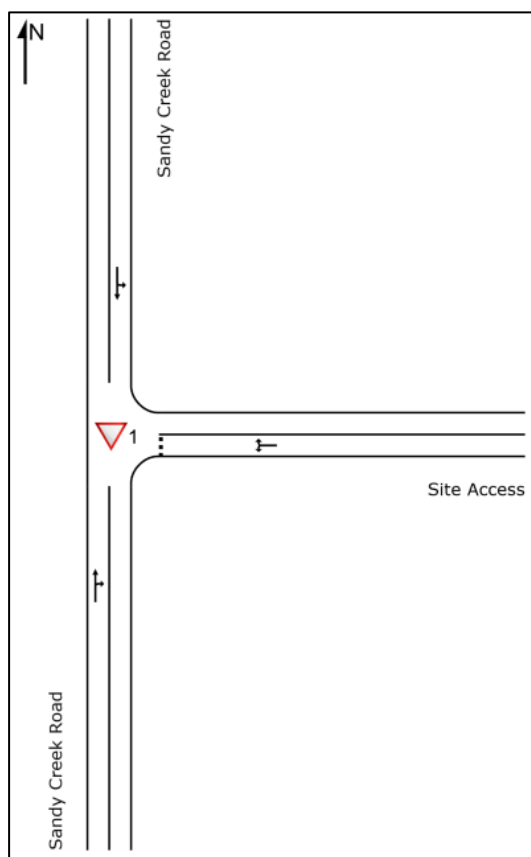

**Figure 5: Modelled Existing Configuration of the Sandy Creek Road Site Access**

Results from the analyses of the Sandy Creek Road site access for the base and design scenarios with the expanded quarry in 2034 (10-year design horizon) is summarised in Table 2.

**Table 2: 2034 Operational Characteristics of the Sandy Creek Road Site Access**

Leg	Movement	2034 Base				2034 Design			
		AM		PM		AM		PM	
		DOS (v/c)	95% Back of Queue (m)	DOS (v/c)	95% Back of Queue (m)	DOS (v/c)	95% Back of Queue (m)	DOS (v/c)	95% Back of Queue (m)
Sandy Creek Road (South)	T	0.03	0	0.06	0	0.03	0	0.06	0
	R	0.03	0	0.06	0	0.03	0	0.06	0
Site Access (East)	L	0.02	1	0.02	1	0.04	1	0.04	2
	R	0.02	1	0.02	1	0.04	1	0.04	2
Sandy Creek Road (North)	L	0.06	0	0.05	0	0.07	0	0.06	0
	T	0.06	0	0.05	0	0.07	0	0.06	0

Note: Practical Maximum Degree of Saturation (DOS) for a priority intersection is 0.80.



The results provided in Table 2 indicate that the Sandy Creek Road site access, as assessed, would operate with satisfactory operating parameters in (2024 and) 2034 with the expanded quarry from a capacity viewpoint.

## 5.2 Intersection Performance of the Beaudesert-Boonah Road / Sandy Creek Road Intersection

The Beaudesert-Boonah Road / Sandy Creek Road intersection includes an auxiliary left (AUL) and channelised right turn (CHR) turn lane treatment.

The modelled existing configuration of the Beaudesert-Boonah Road / Sandy Creek Road intersection, as assessed using SIDRA, is shown as Figure 6.

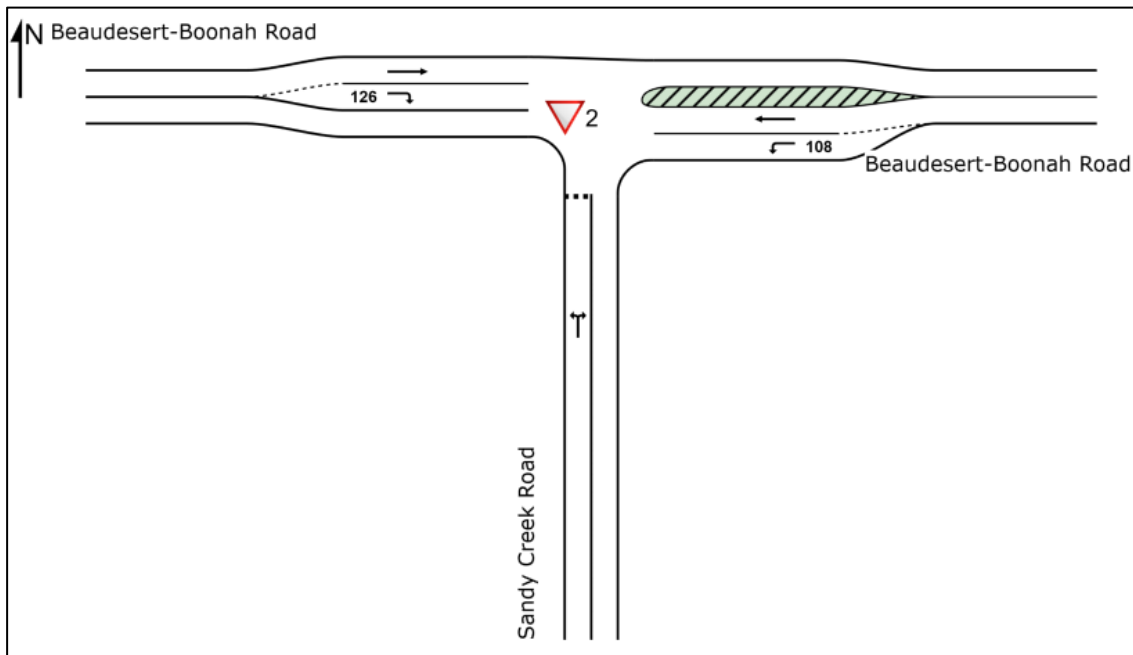

Figure 6: Modelled Existing Configuration of the Beaudesert-Boonah Road / Sandy Creek Road Intersection

Results from the analyses of the Beaudesert-Boonah Road / Sandy Creek Road intersection for the base and design scenarios with the expanded quarry in 2034 (10-year design horizon) are summarised in Table 3.

Table 3: 2034 Operational Characteristics of the Beaudesert-Boonah Road / Sandy Creek Road Intersection

Leg	Movement	2034 Base				2034 Design			
		AM		PM		AM		PM	
		DOS (v/c)	95% Back of Queue (m)	DOS (v/c)	95% Back of Queue (m)	DOS (v/c)	95% Back of Queue (m)	DOS (v/c)	95% Back of Queue (m)
Sandy Creek Road (South)	L	0.12	4	0.17	6	0.15	5	0.22	8
	R	0.12	4	0.17	6	0.15	5	0.22	8
Beaudesert-Boonah Road (East)	L	0.05	0	0.04	0	0.07	0	0.05	0
	T	0.11	0	0.09	0	0.11	0	0.09	0
Beaudesert-Boonah Road (West)	T	0.07	0	0.15	0	0.07	0	0.15	0
	R	0.01	0	0.01	0	0.02	1	0.01	0

Note: Practical Maximum DOS for a priority intersection is 0.80.

The results provided in Table 3 indicate that the Beaudesert-Boonah Road / Sandy Creek Road intersection, as assessed, would operate with satisfactory operating parameters in (2024 and) in 2034 with the expanded quarry from a capacity viewpoint.

## 6 Safety Assessment

Whilst the previous section considers the operation of the key intersections related to the expanded quarry from a capacity viewpoint, safety of these intersections is also required to be assessed.

In consideration of safety, it is important to consider the appropriate geometries and locations of these key intersections. The safety review includes consideration of the following features:

- Sight distances;
- Turn lane warrants;
- Crash data, and
- Any other relevant safety features.

In this instance, there are no other relevant safety features other than sight distances, crash data and the need to consider higher order turn lane treatments, which have all been assessed in the following sections.

### 6.1 Sight Distances

Available sight distances related to the existing Sandy Creek Road site access have been assessed.

The typically sought safe intersection sight distances (**SISD**) and approach sight distances (**ASD**) as per the specifications identified in Austroads' "Guide to Road Design Part 4A: Unsignalised and Signalised Intersection, 2021", and whether the sight distances available comply with the Austroads' specifications are summarised in Table 4.

**Table 4: Review of Sight Distances at the Sandy Creek Road Site Access**

Intersection	Leg of Intersection	Design Speed of Major Road*	Austroads' Typically Sought SISD	Austroads' Typically Sought ASD	Available Sight Distance complies with Austroads' specification	
					SISD	ASD
Sandy Creek Road site access	North	110km/h	285m	193m	Yes	Yes
	South	110km/h	285m	193m	Yes	Yes

\*The analysis has adopted a design speed allowance of 10km/h above the posted speed limit.

The typically sought SISD (285m) related to the site access and the general contours proximate to the site access are illustrated on Figure 7.

From inspection, it is evident that Sandy Creek Road is generally straight and flat proximate to the site access and that sight distances available at the Sandy Creek Road site access would comply with Austroads' specified sight distances.



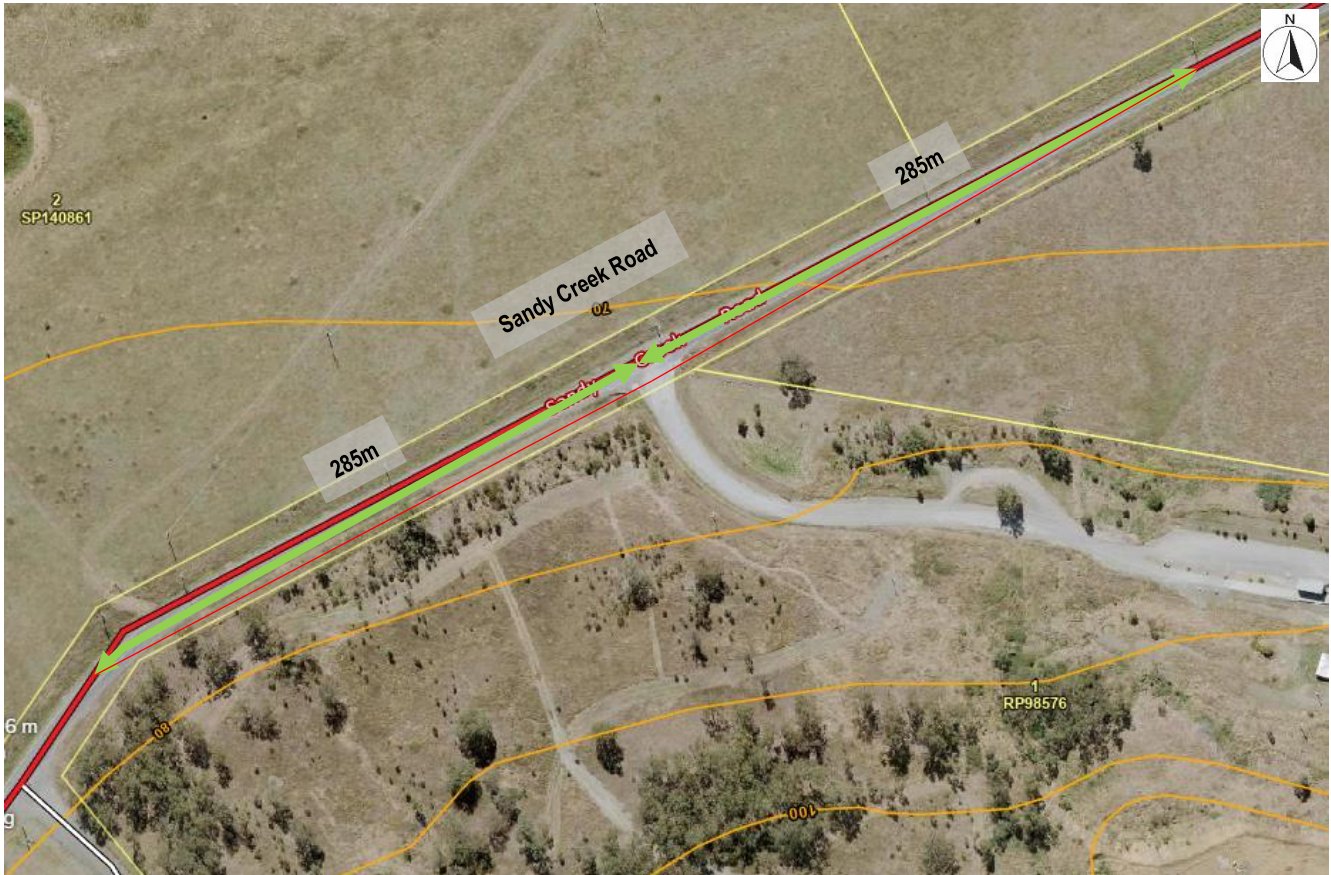

**Figure 7: Contour Map and Sight Distances**

Source: <https://qldglobe.information.qld.gov.au/> [annotations and sight distances added by TTPlus]

## 6.2 Turn Lane Treatments

As previously identified in Section 5.2 of this report, Beaudesert-Boonah Road / Sandy Creek Road intersection already includes AUL / CHR turn lane treatments – these are the highest standard of turn lane treatments typically adopted at a priority-controlled intersection. In addition, the results of SIDRA analyses included in Section 5.2 of this report indicate that the Beaudesert-Boonah Road / Sandy Creek Road intersection, as assessed, would operate with satisfactory operating parameters in 2034 with the expanded quarry from a capacity viewpoint. Therefore, the warrants for the possible need to consider higher order turn lane treatments at the Beaudesert-Boonah Road / Sandy Creek Road intersection are not considered to be necessary to be assessed.

Considering the likely design traffic scenarios for the 10-year design horizon with the expanded quarry (2034 AM and PM design scenarios) ensures that the warrants for the possible need to consider higher order turn lane treatments at the Sandy Creek Road site access are properly tested for all anticipated traffic conditions with the expanded quarry. As no traffic will be turning right into (or left out of) the site access, only the left turn treatment needs to be considered.

The left turn lane treatment that might ordinarily be sought for the Sandy Creek Road site access to ensure appropriately safe operation is determined by plotting the design traffic volumes on the graphs included as *Figure 3.25 Warrants for turn treatments on major roads at unsignalised intersections* within Austroads' *"Guide to Traffic Management Part 6: Intersections, Interchanges and Crossings Management"* (Ref.1) duplicated as Figure 8.

---

<sup>1</sup> *"Guide to Traffic Management Part 6: Intersections, Interchanges and Crossings Management"*, Austroads, 2020.

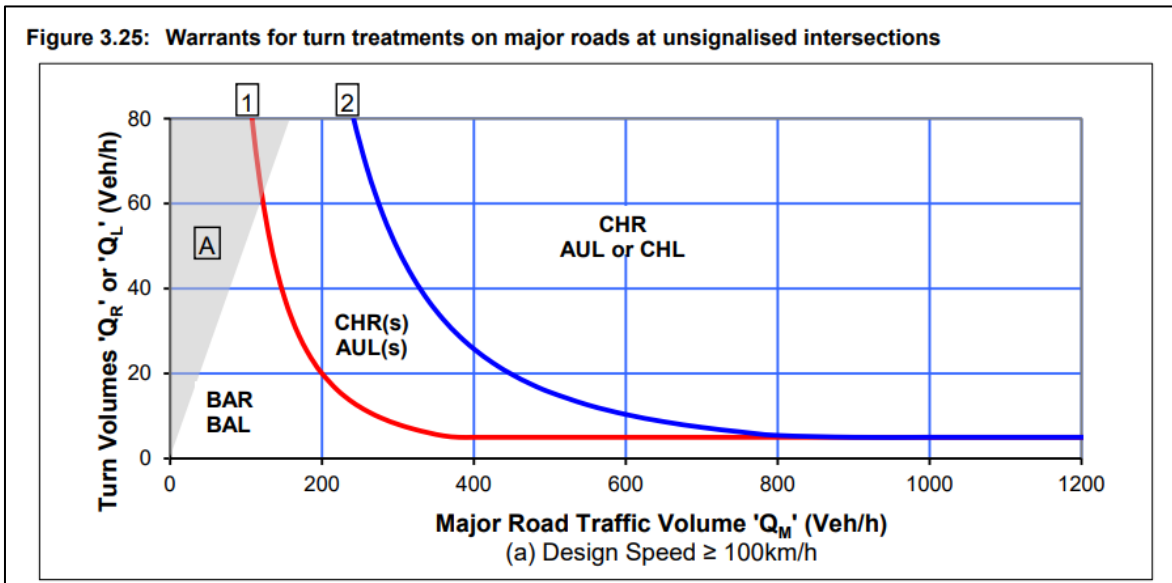
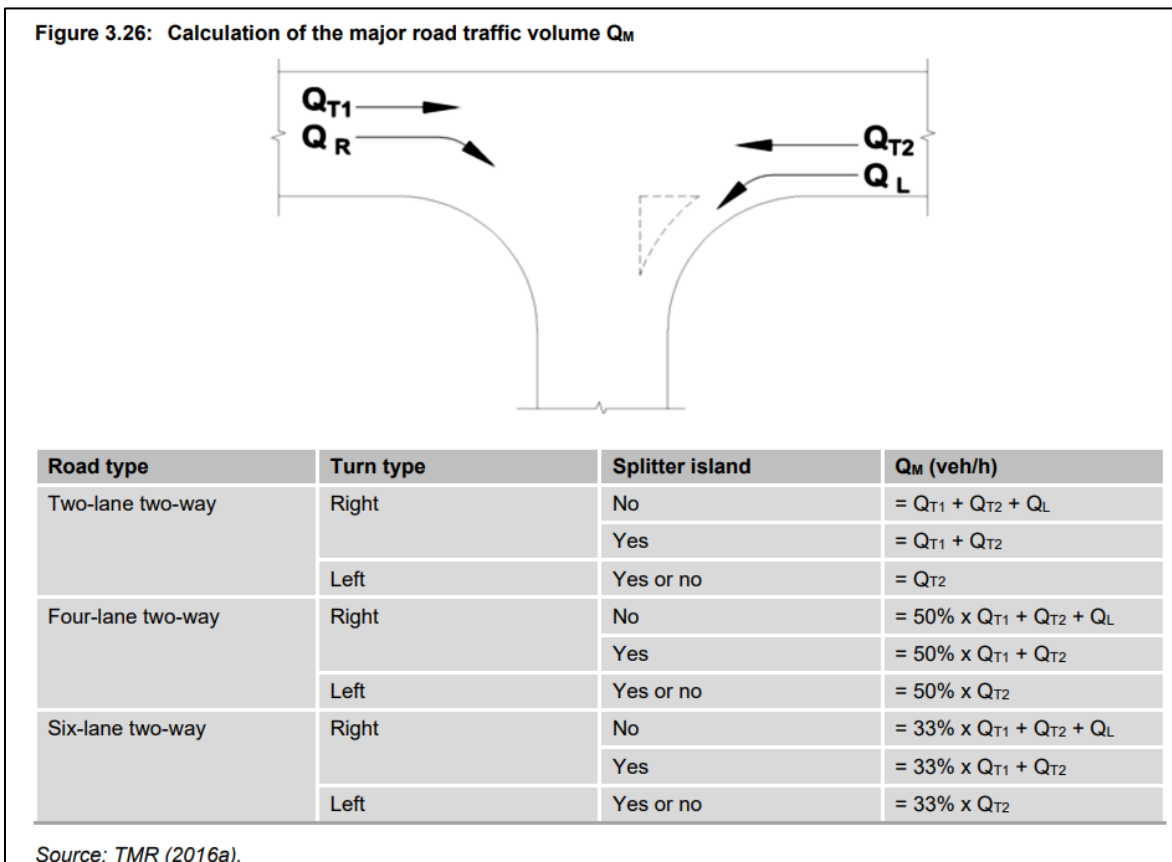

**Figure 8: Warrants for Turn Lane Treatments**

(Source: Ref.1)

The x-axis ( $Q_M$ ) and y-axis ( $Q_R$  and  $Q_L$ ) on these graphs relate to the following:

- $Q_R$  = Right turn traffic volume (vph);
- $Q_L$  = Left turn traffic volume (vph), and
- $Q_M$  = Major road traffic volume (vph) which is calculated in accordance with Figure 3.26: Calculation of the major road traffic volume  $Q_M$  (Ref.1), duplicated as Figure 9.



**Figure 9: Calculation of Major Road Traffic Volumes**

(Source: Ref.1)

### 6.2.1 Turn Lane Assessment of the Sandy Creek Road site access

The proposed quarry would only generate left turning movements from Sandy Creek Road (north) into the site access, therefore only the left turn treatment at the Sandy Creek Road site access is required to be assessed.

By applying the calculations indicated from within Figure 9, the following relevant traffic volume parameters for the left turn and through movements for the 2034 AM and PM design scenarios were established. The traffic volume parameters for each assessment scenario are summarised in Table 5.

**Table 5: Design Traffic Volume Parameters – Sandy Creek Road Site Access**

Scenario	Traffic Movement	Traffic Volume (vph)	
		2034 Design	
		AM	PM
Left Turn Scenario	Q <sub>L</sub>	35	15
	Q <sub>ML</sub> (Q <sub>2</sub> )	66	71

In order to illustrate the identified left turn lane treatment that ordinarily may be sought to be provided at the Sandy Creek Road site access for the above scenario, the traffic volume parameters determined in Table 5 have been plotted on Figure 3.25 of Ref.1 (refer to Figure 8). A design speed of 110km/h for Sandy Creek Road has been adopted.

The coordinates of the assessed case is as approximately indicated on Figure 10.

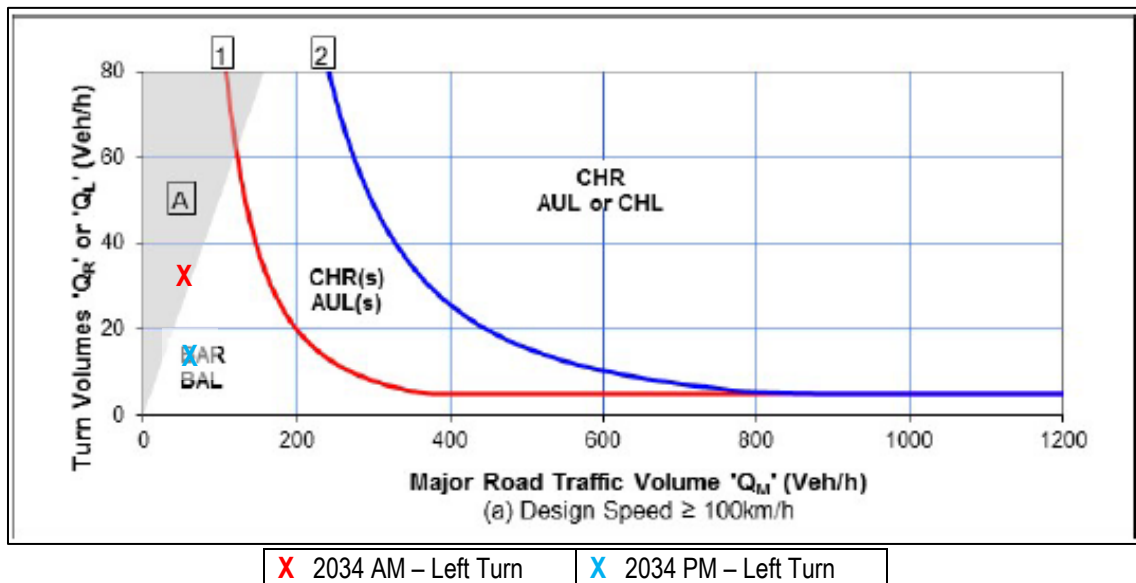

**Figure 10: Warrants for Turn Lane Treatments – Sandy Creek Road Site Access**

Based on the results illustrated within Figure 10, a basic left-turn treatment (**BAL**) would ordinarily be sought to be provided at the Sandy Creek Road site access. This type of turn treatment is the simplest layout and is designed to be as compact (and inexpensive) as possible (Ref.1). A BAL treatment typically has a widened shoulder to assist turning vehicles to move further off the through carriageway making it easier for through vehicles to pass. Figure 11 demonstrates the features of a rural BAL turn treatment, it is noted that the diagram “illustrates principles, not detailed design. Arrows indicate movements relevant to turn type; they do not represent actual pavement markings.”

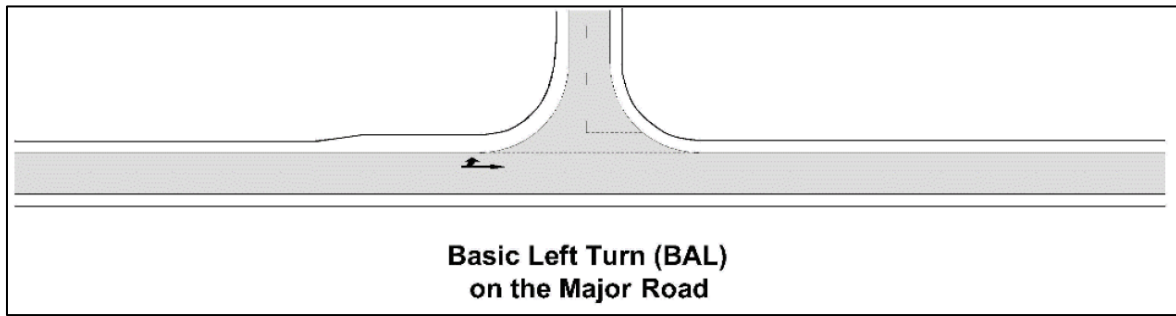

**Figure 11: Rural Basic Left (BAL) Turn Treatment**

(Source: Ref.1)

In this instance, with the plotted points within Figure 10 being significantly below the BAL threshold, the existing geometry evidently being fit-for-purpose, and no history of crashes (refer to Section 6.3 below), it would be reasonable to maintain use of the existing intersection geometry.

Accordingly, in this instance no higher order turn lane treatment(s) are considered to be necessary to ensure safe and efficient operation of the site access.

### 6.3 Crash Statistics

The Queensland Government database (<https://www.data.qld.gov.au/dataset/crash-data-from-queensland-roads>) provides recorded road crash data that can be used to understand what, if any, crash history exists at the key intersections proximate the Subject Site.

The routinely adopted crash frequency and time window metric utilised when issues may be considered to be significant is 3 casualty crashes in the last 5 years.

From review of the crash data from 2017 to the end of 2021 (ie. the most recent 5 years of available data), there have been no reported crashes near the existing Sandy Creek Road site access location. There was one crash (minor injury) in 2018 along Sandy Creek Road between the site access and Beaudesert-Boonah Road / Sandy Creek Road intersection and no crashes at the Beaudesert-Boonah Road / Sandy Creek Road intersection. Whilst crashes can be somewhat arbitrary, it is considered that there are no systematic safety issues at these key intersections or on the surrounding road network that would reasonably require further consideration.

### 6.4 Conclusions in relation to Safety

Based on the results of the SIDRA and turn lane warrant analyses, and review of the historical crash data, the external road network is anticipated to continue to operate safely and efficiently with the proposed expanded quarry.

## 7 Pavement Impact Assessment on Sandy Creek Road

The Neilsens Bromelton Quarry is currently operating pursuant to the aforementioned Consent Order, which allows for extraction of 400,000tpa. Neilsens also holds an EA which allows for the extraction and screening of between 100,000 and 1,000,000tpa.

TTPlus has been advised that there is approximately 7 – 9 years of resource remaining within the whole site of the Neilsens Bromelton Quarry. Based on this, the Neilsens Bromelton Quarry is expected to operate up until around 2030 to 2032 – for the purpose of this pavement impact assessment, it has conservatively been assumed that the life of the quarry will terminate in 2034 (in line with the TIA).

### 7.1 Monetary Contributions for pavement impacts on Sandy Creek Road

TTPlus has been advised that Neilsens and Council entered into an Infrastructure Agreement (IA) in relation to Condition A (xv) of the Development Approval (Court Order 3448 of 2003, dated 29 June 2004). Based on a review of the IA, the contributions associated with the Neilsens Bromelton Quarry are calculated as follows:

**Contributions** = Consumption of Pavement (**g**) + Administration Fee (**h**) + Maintenance Fee (**i**), where  
**g** = \$0.1511957 per actual measured equivalent standard axle (**ESA**) loadings;  
**h** = \$0.02 per tonne (first 25,000 tonnes) + \$0.003 per tonne thereafter, and  
**i** = \$0.0636121 per actual measured ESA loadings.  
where the contributions shall be increased or decreased annually by the RIC1 factor\*

*\*Road and bridge construction Queensland index sourced from Australian Bureau of Statistics.*

*Note: a new term, "Standard Axle Repetition" (SAR) is typically now used to enumerate axle loadings, however it is interchangeable with ESA – for simplicity, ESA has been continued to be used with the reporting herein.*

TTPlus notes that there is no standardised methodology for enumerating pavement contribution, however it is considered that it is appropriate for the expanded quarry to continue to pay monetary contributions for pavement impacts on Sandy Creek Road at this previously determined and agreed rate.

### 7.2 Overlay Works on Sandy Creek Road

Consideration has been given to the potential need to provide some overlay works on Sandy Creek Road at some point in the future as a consequence of the impacts imparted on Sandy Creek Road.

In consideration of this, it is noted that, based on Nearmap aerial imagery it appears that some upgrading works have been implemented on Sandy Creek Road at the end of 2016 / early 2017 and with new linemarking also being implemented ~June / July 2017. Evidently, this provides for an improvement for Sandy Creek Road.

To understand the potential pavement impacts on Sandy Creek Road associated with the expanded quarry and when overlay works may be required to be undertaken, the existing pavement and subgrade conditions of Sandy Creek Road are required to be determined.

Soil Surveys Engineering Pty Ltd (**Soil Surveys Engineering**) was commissioned to undertake a geotechnical investigation of the pavement along Sandy Creek Road. Subsurface conditions were investigated by drilling and sampling eight boreholes (BHA to BHD and BHA1 to BHD1, inclusive) using a 4WD mounted drilling rig. Boreholes BHA, BHB, BHC and BHD were drilled through the existing roadway pavement formations, with probe boreholes drilled in the road shoulder adjacent to the boreholes (Boreholes BHA1, BHB1, BHC1 and BHD1) to obtain bulk samples of the subgrade for laboratory testing.

The locations of the boreholes are illustrated within Figure 12. Soil Surveys Engineering prepared a geotechnical investigation pavement assessment report dated 30 November 2022, provided in Appendix E.



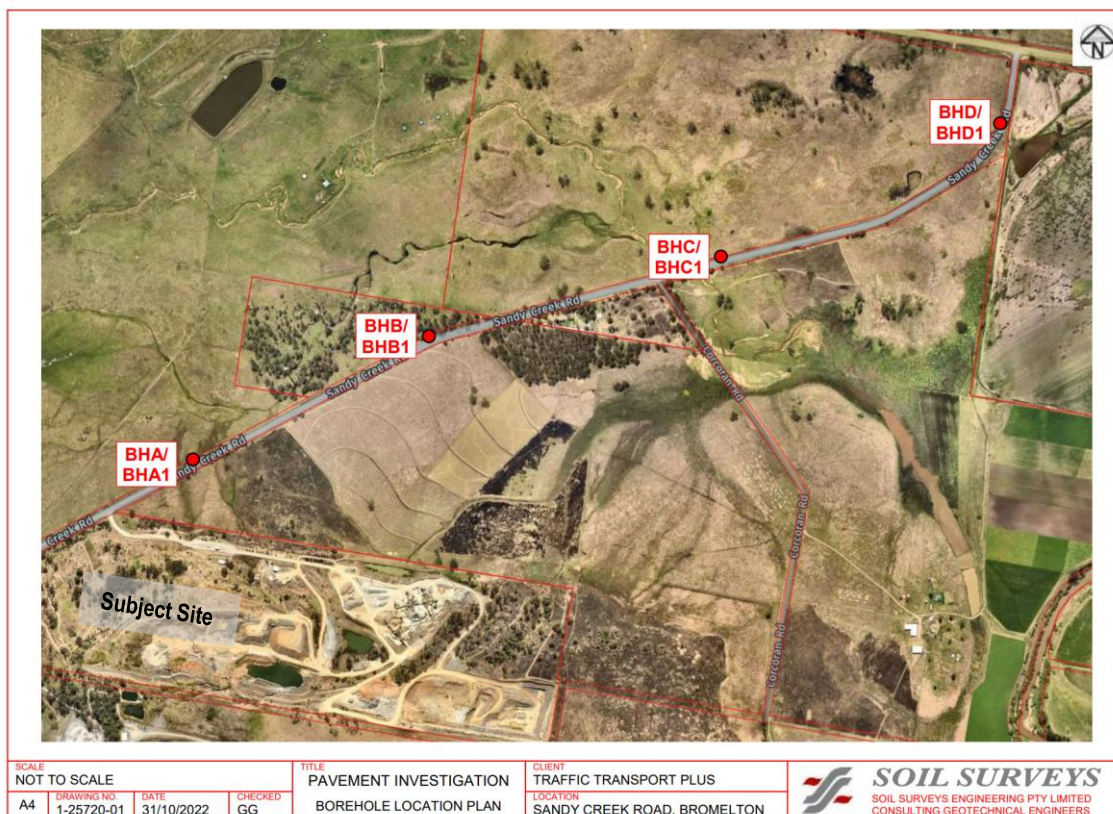

**Figure 12: Locations of the Boreholes – Sandy Creek Road Soil Testing**

*"Subject Site" reference added by TTPlus*

Dynamic Cone Penetrometer (DCP) testing and soaked California Bearing Ratio (CBR) testing were performed on the soil samples taken. Based on the soil testing report, the subsurface profile can be generally described as follows:

- Pavement formation comprising an asphalt wearing surface (10mm thick at all locations) over medium-dense to dense gravel layers (upper layer plus lower layer) ranging in thickness from 390mm to 690mm, and
- Fill material consisting of hard sandy clay, dense sand, and medium dense clayey gravels.

The estimated design equivalent standard axles (ESAs) and the results of the CBR test for each borehole are shown in Table 6. It is noted that these estimates have been calculated using the formula provided in 'Austroads - Guide to Pavement Technology Part 2: Pavement Structural Design' Figure 8.4: Design chart for granular pavements with thin bituminous surfacing.

**Table 6: Existing Pavement Parameters**

Borehole (BH)	Pavement Parameters*	Estimated Design ESAs based on Constructed Pavement (mm) and CBR
BHA	690mm gravel, CBR3.5%	$5.81 \times 10^7$
BHB	490mm gravel, CBR20%	$3.68 \times 10^{13**}$
BHC	390mm gravel, CBR6%	$2.61 \times 10^6$
BHD	590mm gravel, CBR4.5%	$4.46 \times 10^7$
Average		<b><math>4.09 \times 10^7</math></b>

\*Refer to Table 1 and Table 2 of the geotechnical investigation pavement assessment report (Appendix E) for the gravel depth (upper layer and lower layer) and CBR information.

\*\*To provide a conservative pavement assessment, the design ESA of BHB is taken as  $5.81 \times 10^7$  in the calculation of the average (refer to the discussion below).

It is noted that the higher the ('reverse engineered') design ESAs of the pavement, the better the pavement quality is. The pavement quality at BHB is significantly higher compared to other locations. Due to the variation in these estimated design ESAs and to provide a conservative pavement assessment of Sandy Creek Road, for the purpose of this pavement assessment, the estimated design ESA of borehole BHB is assumed to be  $5.81 \times 10^7$  (the same as BHA) when calculating the average design ESAs of Sandy Creek Road; i.e. for the purpose of this assessment the average design ESAs of Sandy Creek Road is calculated as  $4.09 \times 10^7$  [=  $(5.81 \times 10^7 + 5.81 \times 10^7 + 2.61 \times 10^6 + 4.46 \times 10^7) \div 4$ ].

As discussed previously, the identified upgrading works (end of 2016 / early 2017) on Sandy Creek Road would also have likely assisted in improving the holistic residual life of Sandy Creek Road. The adopted average ESA of  $4.09 \times 10^7$  is considered to give a reasonable indication of the residual pavement life.

### **Base Conditions: Heavy Vehicle Traffic Volumes – Sandy Creek Road**

TTPlus has been advised that the annual production rate of the existing quarry in 2020/2021 was slightly more than 350,000tpa (ie. less than 400,000tpa). For the purpose of this assessment, it is conservatively assumed that the annual production rate of the existing quarry in 2021/2022 would have been approximately 350,000tpa. Adopting 300 operational days and the average mass of material per vehicle of 34.13 tonnes per vehicle (same operational parameters as adopted in the traffic impact assessment), results in approximately 34 trucks per day [=  $350,000 \div 34.13 \div 300$ ] for the existing quarry.

The base annual ESAs (without expanded quarry but with the existing quarry (350,000tpa)) and the cumulative ESAs (without expanded quarry but with the existing quarry (350,000tpa)) on Sandy Creek Road are provided in Table 7. The below discussion is provided to assist in understanding the assumptions and calculations undertaken to yield the results presented in this table.

The base annual average daily traffic (**AADT**) and daily heavy vehicle (**HV**) volumes on Sandy Creek Road, and the 2022 peak hour traffic volumes (at the Sandy Creek Road access) have been estimated (AM and PM peak volumes were summed and then multiplied by five) based on the traffic data obtained in the traffic survey undertaken in April 2022. The trips generated by the existing quarry (350,000tpa) have also been included in the 2022 traffic survey, therefore the existing (observed) quarry truck (HV) volumes were subtracted from these calculated base HV volumes, as truck trips associated with the subject quarry would not be subject to background growth (without the proposed expansion).

A growth factor of 2.0% p.a. (compound) has been applied to estimate the 2024 to 2034 base daily HV volumes (without the quarry). The existing quarry trucks (34 trucks per day) were then added back to these base daily HV volumes (without the quarry) to estimate the base daily HV volumes (with the quarry).

Based on the 2022 peak hour intersection survey undertaken at the site access as a part of this study, the estimated year of opening (2024) background heavy vehicle volumes on Sandy Creek Road are calculated as ~151 trucks per day northbound and ~203 trucks per day southbound (without the quarry trucks). These volumes were then multiplied by 365 to calculate annual volumes.

An ESA conversion factor of 3.2 per heavy vehicle has been adopted in the calculation of the base annual ESAs, which is the standard ESA per heavy vehicle conversation factor as advised by DTMR.

It is noted that these base daily volumes would include a significant portion of HVs from the Barro Bromelton Quarry, which would also not be subject to growth, however, as it is difficult to define the number of Barro Bromelton Quarry HVs, they have been included in these base volumes. Additionally, like Neilsens, Barro is unlikely to operate 365 days per year resulting in the base yearly ESA being overestimated. Therefore, the base ESAs are likely a slight overestimation of the base conditions, however in this instance they are still considered to form an appropriate basis for the analyses outlined herein.



**Table 7: Base ESA Estimates – Sandy Creek Road**

Year (starting from the first operational year of the expanded quarry)		Annual HV Volumes – without expanded quarry but with the existing quarry (350,000tpa)		Annual ESAs – without expanded quarry but with the existing quarry (350,000tpa)		Cumulative ESAs - without expanded quarry but with the existing quarry (350,000tpa)	
		A*		B = A x 3.2**		C	
		Northbound	Southbound	Northbound	Southbound	Northbound	Southbound
Year 1	2024	6.53E+04	8.43E+04	2.09E+05	2.70E+05	2.09E+05	2.70E+05
Year 2	2025	5.62E+04	7.55E+04	1.80E+05	2.42E+05	3.89E+05	5.11E+05
Year 3	2026	5.73E+04	7.70E+04	1.83E+05	2.47E+05	5.72E+05	7.58E+05
Year 4	2027	5.84E+04	7.86E+04	1.87E+05	2.51E+05	7.59E+05	1.01E+06
Year 5	2028	5.96E+04	8.02E+04	1.91E+05	2.56E+05	9.50E+05	1.27E+06
Year 6	2029	6.08E+04	8.18E+04	1.95E+05	2.62E+05	1.14E+06	1.53E+06
Year 7	2030	6.20E+04	8.34E+04	1.98E+05	2.67E+05	1.34E+06	1.79E+06
Year 8	2031	6.33E+04	8.51E+04	2.02E+05	2.72E+05	1.55E+06	2.07E+06
Year 9	2032	6.45E+04	8.68E+04	2.06E+05	2.78E+05	1.75E+06	2.34E+06
Year 10	2033	6.58E+04	8.85E+04	2.11E+05	2.83E+05	1.96E+06	2.63E+06
<b>Year 11</b>	<b>2034</b>	<b>6.71E+04</b>	<b>9.03E+04</b>	<b>2.15E+05</b>	<b>2.89E+05</b>	<b>2.18E+06</b>	<b>2.92E+06</b>
Year 12	2035	6.85E+04	9.21E+04	2.19E+05	2.95E+05	2.40E+06	3.21E+06
Year 13	2036	6.98E+04	9.39E+04	2.23E+05	3.01E+05	2.62E+06	3.51E+06
Year 14	2037	7.12E+04	9.58E+04	2.28E+05	3.07E+05	2.85E+06	3.82E+06
Year 15	2038	7.27E+04	9.77E+04	2.32E+05	3.13E+05	3.08E+06	4.13E+06
Year 16	2039	7.41E+04	9.97E+04	2.37E+05	3.19E+05	3.32E+06	4.45E+06
Year 17	2040	7.56E+04	1.02E+05	2.42E+05	3.25E+05	3.56E+06	4.77E+06
Year 18	2041	7.71E+04	1.04E+05	2.47E+05	3.32E+05	3.81E+06	5.11E+06
Year 19	2042	7.86E+04	1.06E+05	2.52E+05	3.38E+05	4.06E+06	5.45E+06
Year 20	2043	8.02E+04	1.08E+05	2.57E+05	3.45E+05	4.31E+06	5.79E+06

\*Yearly HV volumes = [((AM observed + PM observed) traffic volumes without the existing quarry x 5) x growth rate<sup>years</sup> x 365] + [daily quarry trucks of the existing quarry (34vpd) x (300 quarry working days per year)]

\*\*ESAs per HV = 3.2 ESAs/HV (source: DTMR PIA spreadsheet)

**Design Conditions**

The additional ESAs associated with the expanded quarry (+450,000tpa) have been calculated based on the following parameters.

**Table 8: Development ESA Calculations and Adopted Parameters**

<b>All outgoing</b>	450,000	Tonnes per annum	[increase from 350,000tpa to 800,000tpa]	
<b>Tonnes / day</b>	1,500	(a)		
<b>ESAs</b>				
<b>Fleet</b>	<b>Loaded</b>	<b>Unloaded</b>	<b>Payload (tonnes)</b>	<b>Fleet mix</b>
	(b)	(c)	(d)	
Truck & Dog	7.66	0.53	36	86%
B-Double	6.30	0.53	40	5%
Body (Single)	3.57	0.50	13	9%
<b>Weighted Avg</b>	<b>7.22</b>	<b>0.53</b>	<b>34.13</b>	<b>100%</b>
Vehicles per day [(e) = (a) / (d)] = 43.95				
Daily ESAs			Annual ESAs	
<b>OUT</b>	<b>IN</b>	<b>OUT</b>	<b>IN</b>	300 operational days
<b>NB (Loaded)</b>	<b>SB (Unloaded)</b>	<b>NB (Loaded)</b>	<b>SB (Unloaded)</b>	
[(f) = (e) x (b)]	[(g) = (e) x (c)]	= (f) x 300	= (g) x 300	
<b>317</b>	<b>23</b>	<b>95,246</b>	<b>6,952</b>	

Note: NB = northbound, SB = southbound.

Based on the above, the estimated total design ESAs per annum from the expanded quarry is in the order of 95,246 ESAs per annum for the northbound lane and 6,952 ESAs per annum for the southbound lane. The design annual ESAs (with expanded quarry (+450,000tpa)) and the cumulative ESAs (with expanded quarry (+450,000tpa)) on Sandy Creek Road are provided in Table 9.

**Table 9: Design ESAs Including the Expanded Quarry**

Year		Annual ESAs – with expanded quarry (+450,000tpa)		Cumulative ESAs – with expanded quarry (+450,000tpa)	
		D = B (from Table 7) + Development ESAs (95,246 or 6,952 ESAs)		E	
		Northbound	Southbound	Northbound	Southbound
Year 0	2022	3.04E+05	2.77E+05	3.04E+05	2.77E+05
	2023	2.75E+05	2.49E+05	5.79E+05	5.25E+05
Year 1	2024	2.79E+05	2.53E+05	8.58E+05	7.79E+05
Year 2	2025	2.82E+05	2.58E+05	1.14E+06	1.04E+06
Year 3	2026	2.86E+05	2.63E+05	1.43E+06	1.30E+06
Year 4	2027	2.90E+05	2.69E+05	1.72E+06	1.57E+06
Year 5	2028	2.94E+05	2.74E+05	2.01E+06	1.84E+06
Year 6	2029	2.98E+05	2.79E+05	2.31E+06	2.12E+06
Year 7	2030	3.02E+05	2.85E+05	2.61E+06	2.41E+06
Year 8	2031	3.06E+05	2.90E+05	2.91E+06	2.70E+06
Year 9	2032	3.10E+05	2.96E+05	3.22E+06	2.99E+06
Year 10	2033	3.14E+05	3.02E+05	3.54E+06	3.29E+06
<b>Year 11</b>	<b>2034</b>	<b>3.19E+05</b>	<b>3.07E+05</b>	<b>3.86E+06</b>	<b>3.60E+06</b>
Year 12	2035	3.23E+05	3.13E+05	4.18E+06	3.92E+06
Year 13	2036	3.28E+05	3.20E+05	4.51E+06	4.23E+06
Year 14	2037	3.32E+05	3.26E+05	4.84E+06	4.56E+06
Year 15	2038	3.37E+05	3.32E+05	5.18E+06	4.89E+06
Year 16	2039	3.42E+05	3.39E+05	5.52E+06	5.23E+06
Year 17	2040	3.47E+05	3.45E+05	5.87E+06	5.58E+06
Year 18	2041	3.52E+05	3.52E+05	6.22E+06	5.93E+06
Year 19	2042	3.04E+05	2.77E+05	3.04E+05	2.77E+05
Year 20	2043	2.75E+05	2.49E+05	5.79E+05	5.25E+05

Based on the above table, the estimated design ESA of Sandy Creek Road of  $4.09 \times 10^7$  is not reached by the time the quarry would cease operation in 2024, or even within the time period considered.

Based on the above assessment no overlay works are required to be undertaken on Sandy Creek Road as a result of the expanded quarry, even if the quarry were to operate longer than the expected quarry life (~2034 for the purpose of this assessment).

## 8 Pavement Contributions for Impacts on State-controlled Roads

TTPlus has adopted the current standardised method of determining appropriate contributions related to pavement impacts on the SCR network associated with extractive industry uses. In consideration of this, the pavement contributions for pavement impacts associated with the expanded quarry on SCRs have been determined using the latest version of DTMR’s “Guide to Traffic Impact Assessment 2018” (GTIA).

### 8.1 Assessment Parameters

The following assessment parameters have been adopted in this pavement contribution assessment:

- Annual production rate: 800,000tpa;
- First assessment year: 2024;
- AADT data: 2021 data sourced from DTMR;
- AADT growth rate: 2.0% p.a. (compound – which is consistent with the traffic growth rate adopted in the traffic impact assessment within this report), and
- Marginal Cost: 2020 data sourced from DTMR.

### 8.2 Project Operational Parameters

The likely operational parameters of the expanded quarry are discussed in Section 4.3 of this report.

### 8.3 Pavement Contribution

The calculations of the pavement contributions for the pavement impacts associated with the expanded quarry on SCRs, undertaken based on DTMR’s GTIA, are illustrated in Table 10 (for production from 1tpa to 800,000tpa). An electronic copy of the Excel file can be provided (if required) upon request. A copy of the case of the pavement contribution assessment of 800,000tpa has been included in Appendix F of this report.

**Table 10: Appropriate Pavement Contribution of the Neilsens Bromelton Quarry (for production from 1tpa to 800,000tpa)**

Production Rate (tpa)	Pavement Contribution (cents / tonne)
1 – 100,000	0.00
100,001 – 200,000	3.23
200,001 – 300,000	3.23
300,001 – 400,000	4.12
400,001 – 500,000	8.60
500,001 – 600,000	13.97
600,001 – 700,000	13.97
700,001 – 800,000	13.97

As noted in the introduction of this report, the subject development application must result in a fresh approval – accordingly completely new conditions are required.

Accordingly, and for the sake of consistency and adopting the current standardised method included in DTMR’s GTIA (and thus most accurate), TTPlus considers that the pavement contributions for the production of the first 400,000tpa of the Neilsens Bromelton Quarry should hereafter also be paid in accordance with the pavement contributions calculated within Table 10.

## 9 Summary of Findings

---

TTPlus has been commissioned by Neilsens to prepare a traffic and pavement impact assessment report as part of a development application for the proposed expansion of the eastern quarry footprint of the Neilsens Bromelton Quarry located at 291 Sandy Creek Road, Bromelton, properly described as Lot 1 on RP98576 (**Subject Site**).

The Neilsens Bromelton Quarry is currently operating pursuant to Consent Order for Material Change of Use – Development Permit for Extractive Industry (ref: 3448 of 2003) granted on 23 June 2004 (**Consent Order**), which allows for extraction of 400,000 tonnes per annum (**tpa**) of material in stages. Neilsens also holds an Environmental Authority for Environmentally Relevant Activities 16(2)(b) and 16(3)(b) which allow for the extraction and screening of between 100,000 and 1,000,000tpa.

The subject application for the Neilsens Bromelton Quarry seeks approval to extend the eastern quarry footprint north and be permitted to extract up to 800,000tpa (**expanded quarry**). No changes to the other traffic-related aspects of the operation are proposed (eg. hours of operation, access, staff numbers and haulage routes etc). It is understood that there is approximately 3 – 4 years of resource remaining within the approved Stage 4 footprint and an additional 4 – 5 years of resource available within the extended eastern quarry footprint.

The site layout plan for the expanded quarry is included as Appendix A.

### Site Access

The existing site access on Sandy Creek Road is approximately 2.87km south (measured along Sandy Creek Road) of the Beaudesert-Boonah Road / Sandy Creek Road intersection and is proposed to be utilised as the access for the site. The existing form of the intersection is anticipated to continue to operate satisfactorily from both safety and capacity viewpoints.

### Transport Routes

The existing transport routes related to the Subject Site are Sandy Creek Road (north), Beaudesert-Boonah Road (east / west) and Mount Lindesay Highway (north / south).

The existing transport routes are illustrated by the blue lines on Figure 2. These existing transport routes are proposed to be continued to be utilised for haulage related to the expanded quarry.

### Traffic Impact Assessment and Safety Assessment

The results of the SIDRA analyses included in Section 5 of this report illustrate that the existing Sandy Creek Road site access and the Beaudesert-Boonah Road / Sandy Creek Road intersection, as assessed, would operate with satisfactory operating parameters with the expanded quarry from a capacity viewpoint.

Based on the results of the SIDRA analysis, the turn lane treatment assessment and review of the historical crash data, the external road network is anticipated to continue to operate safely and efficiently.

### Pavement Contributions and works for Sandy Creek Road

TTPlus has been advised that Neilsens and Council entered into an Infrastructure Agreement in relation to Condition A (xv) of the Development Approval (Court Order 3448 of 2003 dated 29 June 2004). TTPlus considers that it is appropriate for the expanded quarry to continue to pay monetary contributions for pavement impacts on Sandy Creek Road at this previously determined and agreed rate.

Based on the assessment outlined within Section 7.2, no overlay works are required to be undertaken on Sandy Creek Road as a result of the expanded quarry, even if the quarry were to operate for an additional 10 years after the forecast end of life (~2034 for the purpose of this assessment).

### Pavement Contributions for Impacts on State-controlled Roads

An assessment of contributions for impacts on the state-controlled road network has been undertaken in accordance with DTMR's GTIA. The calculated pavement contributions for impacts associated with the expanded quarry on state-controlled roads, determined using DTMR's GTIA, are illustrated in Table 10 (for production from 1tpa to 800,000tpa).

TTPlus considers that the pavement contributions for the production of the first 400,000tpa of the Neilsens Bromelton Quarry should also be paid in accordance with the pavement contributions calculated within Table 10 as part of the new approval, rather than retention of the conditions in the previous Consent Order.

### Conclusion

Based on the assessment and recommendations within this report, the expanded quarry can be approved from a traffic engineering perspective, subject to reasonable and relevant conditions.

# **Appendix A**

## **Site Layout Plan**

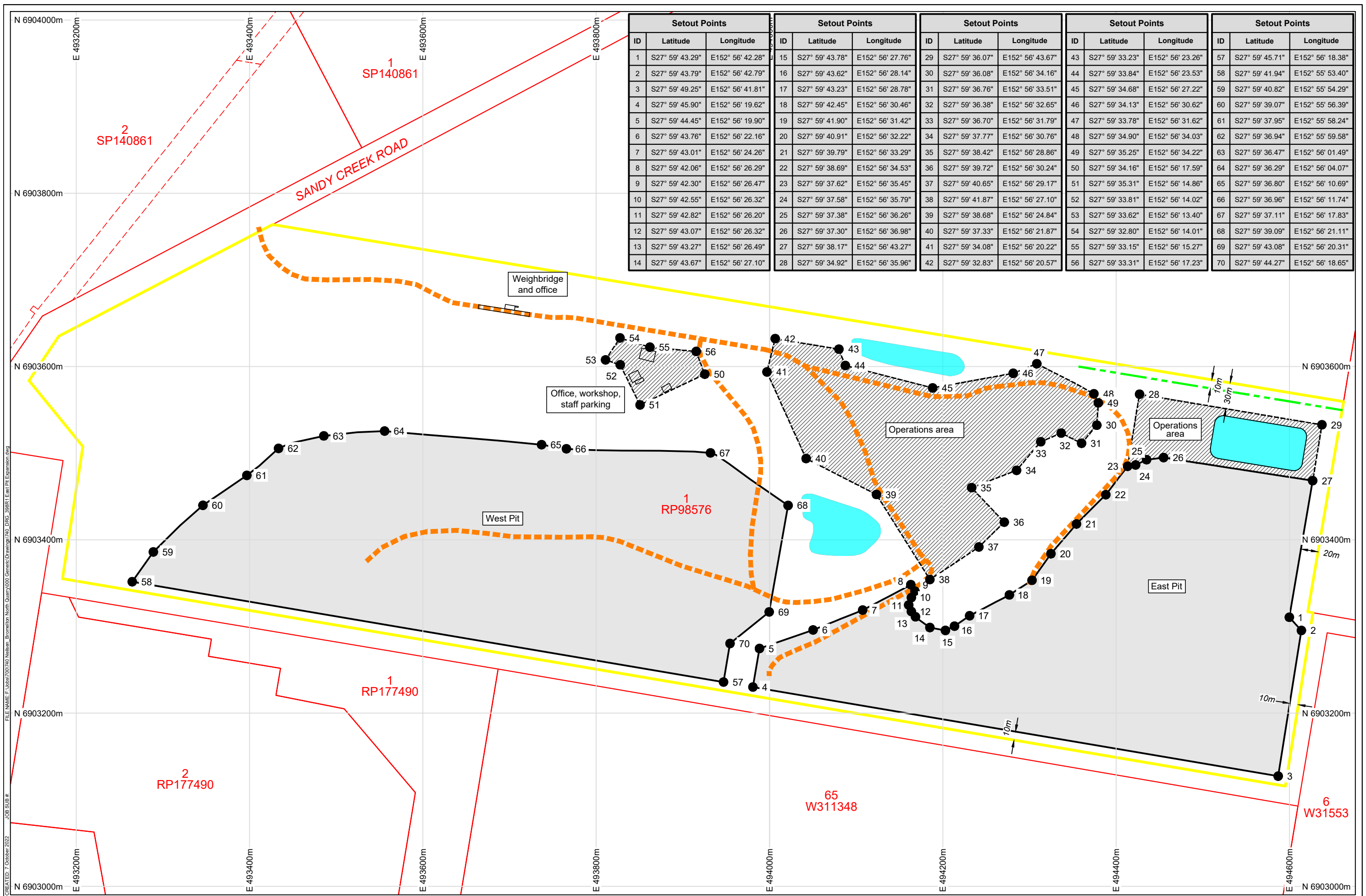

REV	DESCRIPTION	DATE	BY
1	Pit avoids remnant vegetation	04/10/22	MR

Data Sources:  
 Photography: Groundwork Plus RPA Survey, Captured 2022-07-26  
 Topography: Cadastral: © The State of Queensland (DNRM) 2022  
 Ecosystem: Other: Background Photography: © The State of Queensland (DNRM) 2019  
 THESE DESIGNS AND PLANS ARE COPYRIGHT AND ARE NOT TO BE USED OR REPRODUCED WHOLLY OR IN PART OR TO BE USED ON ANY PROJECT WITHOUT THE WRITTEN PERMISSION OF GROUNDWORK PLUS PTY LTD. ABN: 13 609 422 791

**Legend:**

- Site Boundary (Yellow line)
- Cadastral Boundary (Red line)
- Easement Boundary (Dashed red line)
- Proposed Extraction Boundary (Black line)
- Water Storage / Sediment Basin (Cyan area)
- Operations Area Boundary (Dashed black line)
- Internal Haul Road (Dashed orange line)
- Vegetation Buffer (Dashed green line)

PROJECT: Bromelton North	TITLE: East Pit Expansion
CLIENT: Neilsens Quality Gravels Pty Ltd	SCALE: 1:4,000
GROUNDWORK plus	DRAWING NUMBER: 740.DRG.398
PH: +61 7 3871 0411	REVISION: 1
WWW.GROUNDWORK.COM.AU	DATUM: HORIZONTAL / VERTICAL / ZONE
DATE: 7 October 2022	MGA / AHD / 56
PRINTED: 7 October 2022	CHECKED: MB



# **Appendix B**

## **Traffic Volume Diagrams**

Note:

1. all units are vehicles per hour
2. 20 (30) = Weekday AM peak hour traffic volume (Weekday PM peak hour traffic volume)

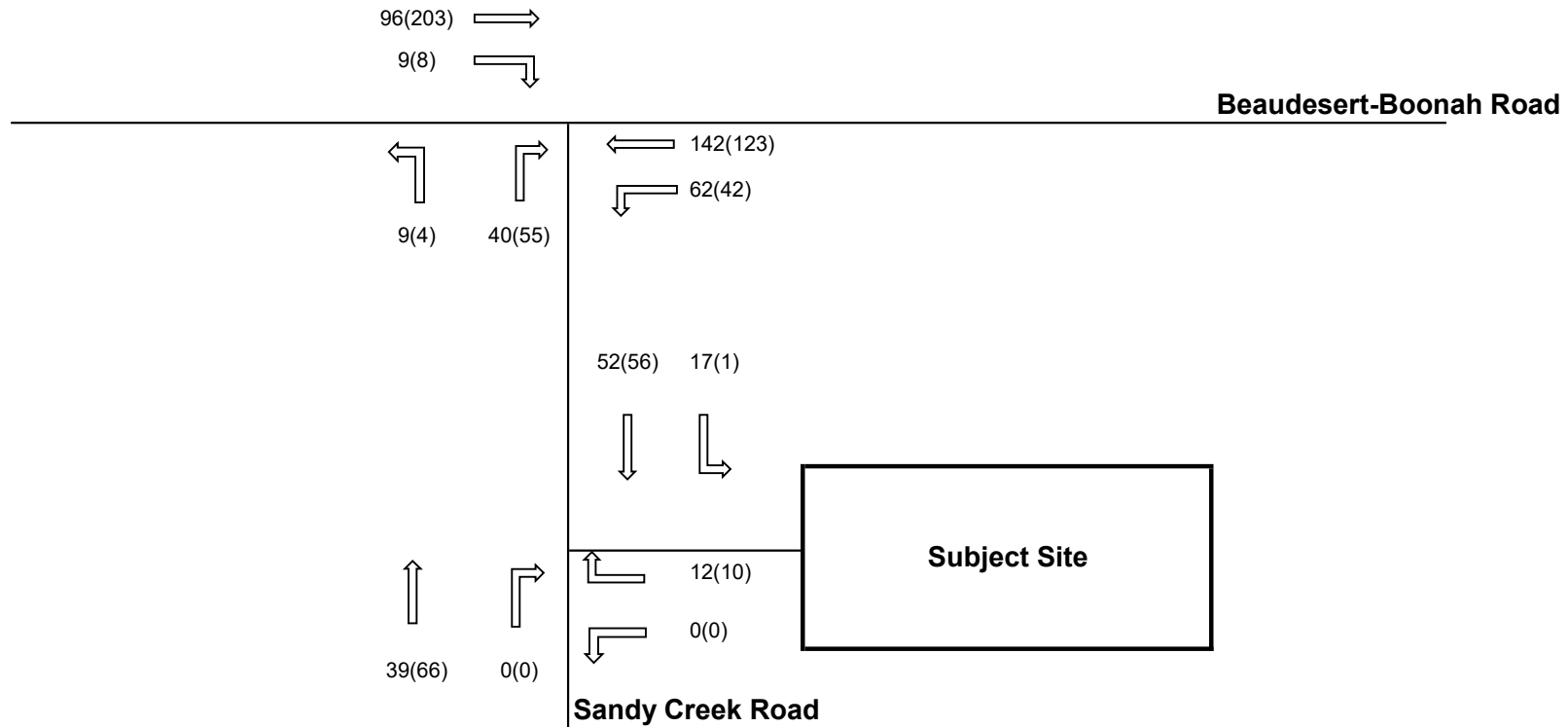

<b>Neilsens Bromelton Quarry</b>	<b>2022 Observed Traffic Volumes</b>	December 2022
	<b>TRAFFIC TRANSPORT plus</b>	TTPlus Project No: 10551
		<b>Figure B1</b>

Note:

1. all units are vehicles per hour
2. 20 (30) = Weekday AM peak hour traffic volume (Weekday PM peak hour traffic volume)

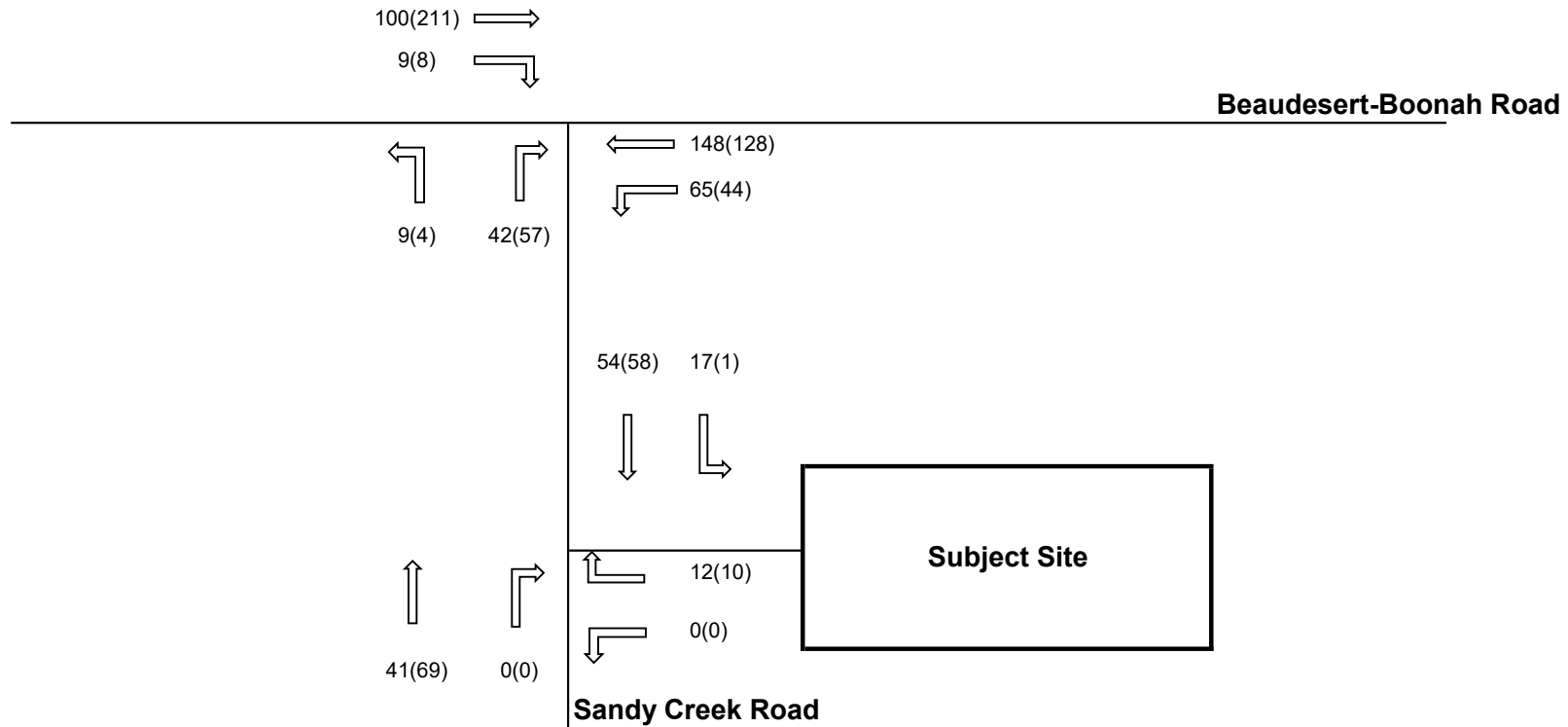

<b>Neilsens Bromelton Quarry</b>	<b>2024 Base Traffic Volumes</b>	December 2022
	<b>TRAFFIC TRANSPORT plus</b>	TTPlus Project No: 10551
		<b>Figure B2</b>

Note:

1. all units are vehicles per hour
2. 20 (30) = Weekday AM peak hour traffic volume (Weekday PM peak hour traffic volume)

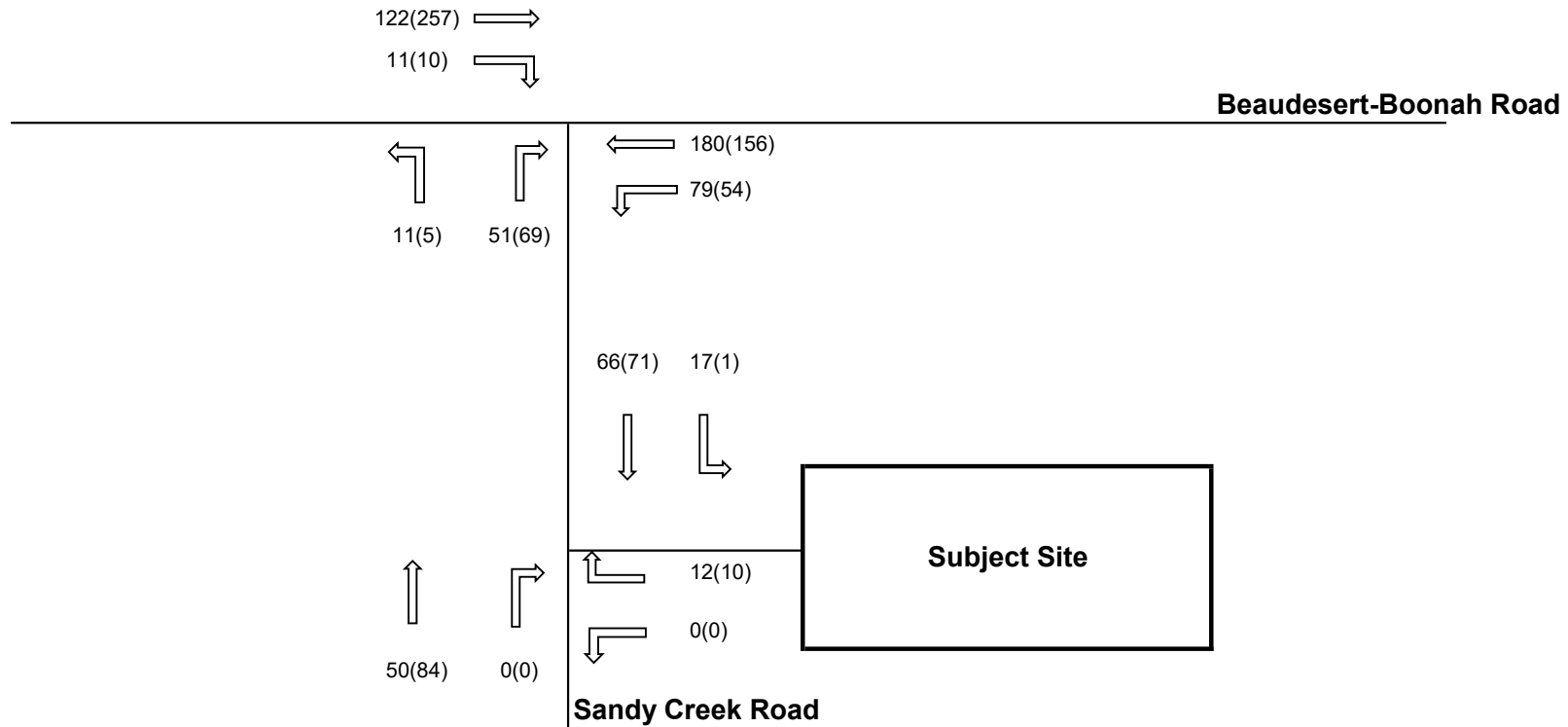

<b>Neilsens Bromelton Quarry</b>	<b>2034 Base Traffic Volumes</b>	December 2022
	<b>TRAFFIC TRANSPORT plus</b>	TTPlus Project No: 10551
		<b>Figure B3</b>

Note:

1. all units are vehicles per hour
2. 20 (30) = Weekday AM peak hour traffic volume (Weekday PM peak hour traffic volume)

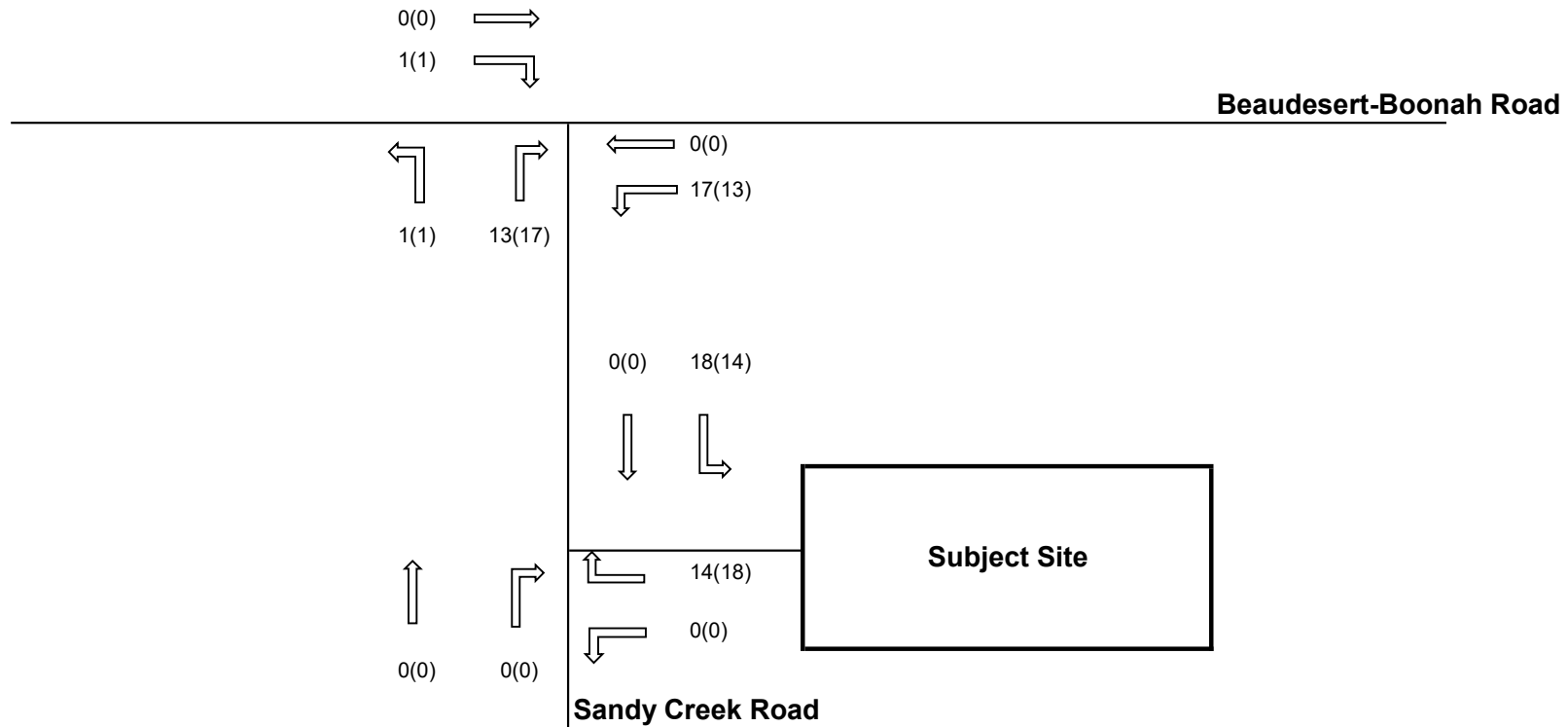

<b>Neilsens Bromelton Quarry</b>	<b>Trip Generation associated with the Proposed Quarry</b>	December 2022
		TTPlus Project No: 10551
	<b>TRAFFIC TRANSPORT</b> plus	<b>Figure B4</b>

Note:

1. all units are vehicles per hour
2. 20 (30) = Weekday AM peak hour traffic volume (Weekday PM peak hour traffic volume)

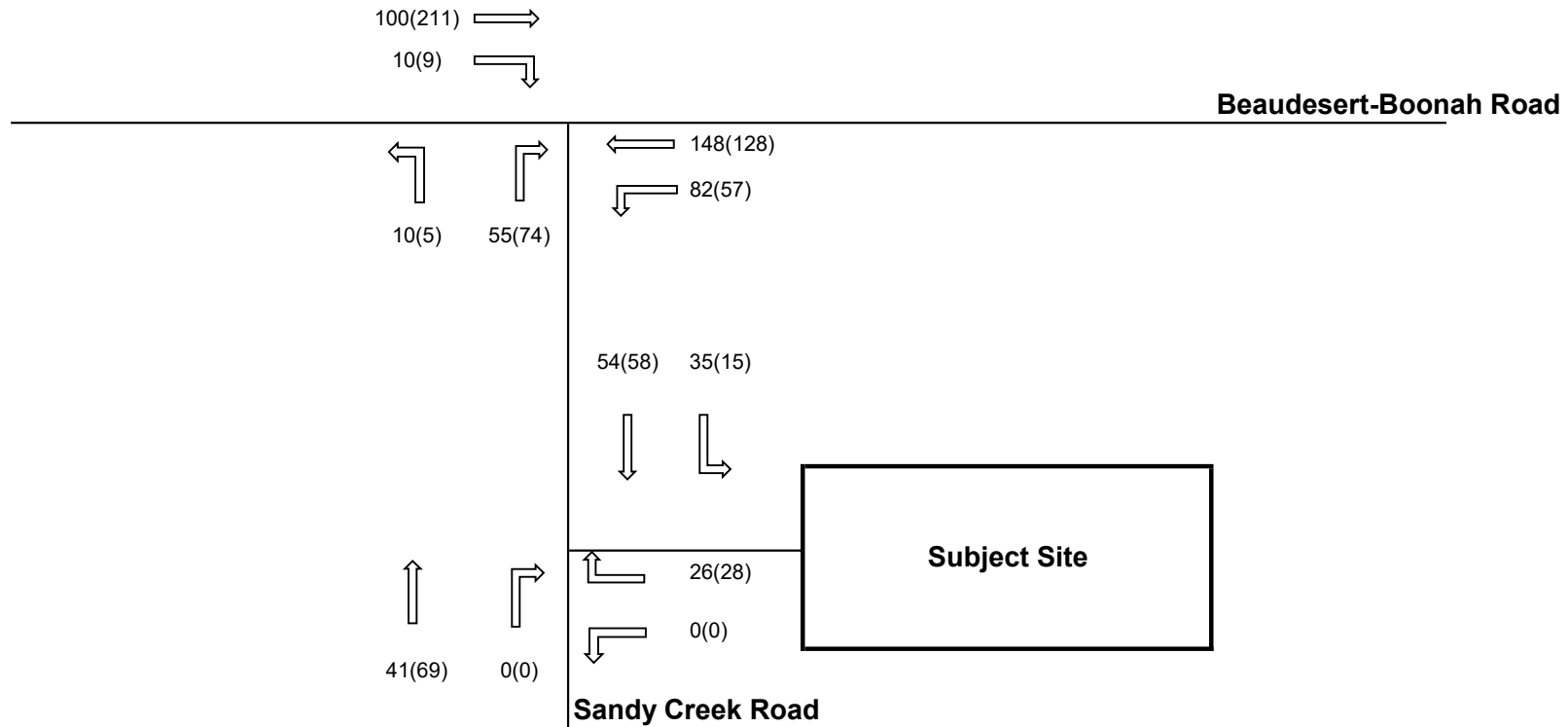

<b>Neilsens Bromelton Quarry</b>	<b>2024 Design Traffic Volumes</b>	December 2022
	<b>TRAFFIC TRANSPORT plus</b>	TTPlus Project No: 10551
		<b>Figure B5</b>

Note:

1. all units are vehicles per hour
2. 20 (30) = Weekday AM peak hour traffic volume (Weekday PM peak hour traffic volume)

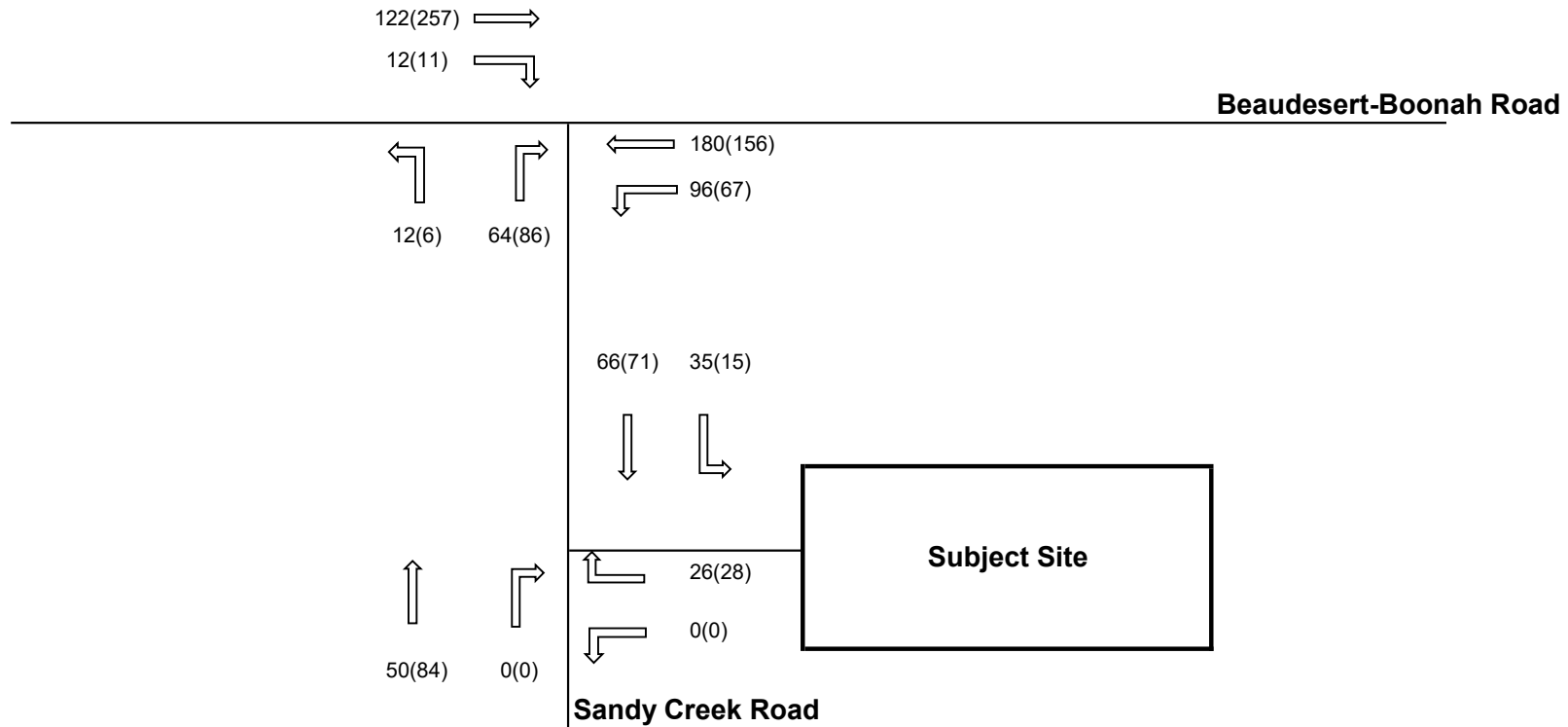

<b>Neilsens Bromelton Quarry</b>	<b>2034 Design Traffic Volumes</b>	December 2022
	<b>TRAFFIC TRANSPORT plus</b>	TTPlus Project No: 10551
		<b>Figure B6</b>



# **Appendix C**

## **Results of SIDRA Analyses**

# MOVEMENT SUMMARY

## Site: 1 [2034 Base AM Peak Hour (Site Folder: General)]

Sandy Creek Road Site Access  
 Site Category: Existing Design  
 Give-Way (Two-Way)

Vehicle Movement Performance														
Mov ID	Turn	INPUT VOLUMES		DEMAND FLOWS		Deg. Satn	Aver. Delay	Level of Service	95% BACK OF QUEUE		Prop. Que	Effective Stop Rate	Aver. No. Cycles	Aver. Speed
		[ Total veh/h ]	[ HV % ]	[ Total veh/h ]	[ HV % ]				[ Veh. veh ]	[ Dist m ]				
South: Sandy Creek Road														
2	T1	50	30.0	53	30.0	0.033	0.0	LOS A	0.0	0.1	0.01	0.01	0.01	59.9
3	R2	1	80.0	1	80.0	0.033	7.0	LOS A	0.0	0.1	0.01	0.01	0.01	53.6
Approach		51	31.0	54	31.0	0.033	0.2	NA	0.0	0.1	0.01	0.01	0.01	59.8
East: Site Access														
4	L2	1	80.0	1	80.0	0.018	6.9	LOS A	0.1	0.7	0.25	0.58	0.25	49.7
6	R2	12	80.0	13	80.0	0.018	7.4	LOS A	0.1	0.7	0.25	0.58	0.25	49.1
Approach		13	80.0	14	80.0	0.018	7.4	LOS A	0.1	0.7	0.25	0.58	0.25	49.1
North: Sandy Creek Road														
7	L2	17	80.0	18	80.0	0.058	6.5	LOS A	0.0	0.0	0.00	0.12	0.00	54.2
8	T1	66	30.0	69	30.0	0.058	0.0	LOS A	0.0	0.0	0.00	0.12	0.00	59.6
Approach		83	40.2	87	40.2	0.058	1.3	NA	0.0	0.0	0.00	0.12	0.00	58.4
All Vehicles		147	40.5	155	40.5	0.058	1.5	NA	0.1	0.7	0.03	0.12	0.03	57.9

Site Level of Service (LOS) Method: Delay (SIDRA). Site LOS Method is specified in the Parameter Settings dialog (Site tab).

Vehicle movement LOS values are based on average delay per movement.

Minor Road Approach LOS values are based on average delay for all vehicle movements.

NA: Intersection LOS and Major Road Approach LOS values are Not Applicable for two-way sign control since the average delay is not a good LOS measure due to zero delays associated with major road movements.

Delay Model: SIDRA Standard (Geometric Delay is included).

Queue Model: SIDRA Standard.

Gap-Acceptance Capacity: SIDRA Standard (Akçelik M3D).

HV (%) values are calculated for All Movement Classes of All Heavy Vehicle Model Designation.

# MOVEMENT SUMMARY

## ▼ Site: 1 [2034 Base PM Peak Hour (Site Folder: General)]

Sandy Creek Road Site Access  
 Site Category: Existing Design  
 Give-Way (Two-Way)

Vehicle Movement Performance														
Mov ID	Turn	INPUT VOLUMES		DEMAND FLOWS		Deg. Satn	Aver. Delay	Level of Service	95% BACK OF QUEUE		Prop. Que	Effective Stop Rate	Aver. No. Cycles	Aver. Speed
		[ Total veh/h ]	[ HV % ]	[ Total veh/h ]	[ HV % ]				[ Veh. veh ]	[ Dist m ]				
South: Sandy Creek Road														
2	T1	84	30.0	88	30.0	0.055	0.0	LOS A	0.0	0.1	0.01	0.01	0.01	60.0
3	R2	1	80.0	1	80.0	0.055	6.9	LOS A	0.0	0.1	0.01	0.01	0.01	53.7
Approach		85	30.6	89	30.6	0.055	0.1	NA	0.0	0.1	0.01	0.01	0.01	59.9
East: Site Access														
4	L2	1	80.0	1	80.0	0.015	6.9	LOS A	0.0	0.6	0.28	0.59	0.28	49.6
6	R2	10	80.0	11	80.0	0.015	7.7	LOS A	0.0	0.6	0.28	0.59	0.28	48.9
Approach		11	80.0	12	80.0	0.015	7.6	LOS A	0.0	0.6	0.28	0.59	0.28	49.0
North: Sandy Creek Road														
7	L2	1	80.0	1	80.0	0.047	6.5	LOS A	0.0	0.0	0.00	0.01	0.00	54.5
8	T1	71	30.0	75	30.0	0.047	0.0	LOS A	0.0	0.0	0.00	0.01	0.00	60.0
Approach		72	30.7	76	30.7	0.047	0.1	NA	0.0	0.0	0.00	0.01	0.00	59.9
All Vehicles		168	33.9	177	33.9	0.055	0.6	NA	0.0	0.6	0.02	0.05	0.02	59.0

Site Level of Service (LOS) Method: Delay (SIDRA). Site LOS Method is specified in the Parameter Settings dialog (Site tab).

Vehicle movement LOS values are based on average delay per movement.

Minor Road Approach LOS values are based on average delay for all vehicle movements.

NA: Intersection LOS and Major Road Approach LOS values are Not Applicable for two-way sign control since the average delay is not a good LOS measure due to zero delays associated with major road movements.

Delay Model: SIDRA Standard (Geometric Delay is included).

Queue Model: SIDRA Standard.

Gap-Acceptance Capacity: SIDRA Standard (Akçelik M3D).

HV (%) values are calculated for All Movement Classes of All Heavy Vehicle Model Designation.

# MOVEMENT SUMMARY

## Site: 1 [2034 Design AM Peak Hour (Site Folder: General)]

Sandy Creek Road Site Access  
 Site Category: Existing Design  
 Give-Way (Two-Way)

Vehicle Movement Performance														
Mov ID	Turn	INPUT VOLUMES		DEMAND FLOWS		Deg. Satn	Aver. Delay	Level of Service	95% BACK OF QUEUE		Prop. Que	Effective Stop Rate	Aver. No. Cycles	Aver. Speed
		[ Total veh/h ]	[ HV % ]	[ Total veh/h ]	[ HV % ]				[ Veh. veh ]	[ Dist m ]				
South: Sandy Creek Road														
2	T1	50	30.0	53	30.0	0.033	0.0	LOS A	0.0	0.1	0.01	0.01	0.01	59.9
3	R2	1	80.0	1	80.0	0.033	7.2	LOS A	0.0	0.1	0.01	0.01	0.01	53.6
Approach		51	31.0	54	31.0	0.033	0.2	NA	0.0	0.1	0.01	0.01	0.01	59.8
East: Site Access														
4	L2	1	80.0	1	80.0	0.037	6.9	LOS A	0.1	1.4	0.28	0.60	0.28	49.6
6	R2	26	80.0	27	80.0	0.037	7.6	LOS A	0.1	1.4	0.28	0.60	0.28	49.0
Approach		27	80.0	28	80.0	0.037	7.5	LOS A	0.1	1.4	0.28	0.60	0.28	49.0
North: Sandy Creek Road														
7	L2	35	80.0	37	80.0	0.074	6.5	LOS A	0.0	0.0	0.00	0.20	0.00	53.9
8	T1	66	30.0	69	30.0	0.074	0.0	LOS A	0.0	0.0	0.00	0.20	0.00	59.2
Approach		101	47.3	106	47.3	0.074	2.3	NA	0.0	0.0	0.00	0.20	0.00	57.3
All Vehicles		179	47.6	188	47.6	0.074	2.5	NA	0.1	1.4	0.05	0.20	0.05	56.5

Site Level of Service (LOS) Method: Delay (SIDRA). Site LOS Method is specified in the Parameter Settings dialog (Site tab).

Vehicle movement LOS values are based on average delay per movement.

Minor Road Approach LOS values are based on average delay for all vehicle movements.

NA: Intersection LOS and Major Road Approach LOS values are Not Applicable for two-way sign control since the average delay is not a good LOS measure due to zero delays associated with major road movements.

Delay Model: SIDRA Standard (Geometric Delay is included).

Queue Model: SIDRA Standard.

Gap-Acceptance Capacity: SIDRA Standard (Akçelik M3D).

HV (%) values are calculated for All Movement Classes of All Heavy Vehicle Model Designation.

# MOVEMENT SUMMARY

## Site: 1 [2034 Design PM Peak Hour (Site Folder: General)]

Sandy Creek Road Site Access  
 Site Category: Existing Design  
 Give-Way (Two-Way)

Vehicle Movement Performance														
Mov ID	Turn	INPUT VOLUMES		DEMAND FLOWS		Deg. Satn	Aver. Delay	Level of Service	95% BACK OF QUEUE		Prop. Que	Effective Stop Rate	Aver. No. Cycles	Aver. Speed
		[ Total veh/h ]	[ HV % ]	[ Total veh/h ]	[ HV % ]				[ Veh. veh ]	[ Dist m ]				
South: Sandy Creek Road														
2	T1	84	30.0	88	30.0	0.055	0.0	LOS A	0.0	0.1	0.01	0.01	0.01	59.9
3	R2	1	80.0	1	80.0	0.055	7.1	LOS A	0.0	0.1	0.01	0.01	0.01	53.7
Approach		85	30.6	89	30.6	0.055	0.1	NA	0.0	0.1	0.01	0.01	0.01	59.9
East: Site Access														
4	L2	1	80.0	1	80.0	0.042	6.9	LOS A	0.1	1.6	0.30	0.61	0.30	49.5
6	R2	28	80.0	29	80.0	0.042	7.8	LOS A	0.1	1.6	0.30	0.61	0.30	48.8
Approach		29	80.0	31	80.0	0.042	7.8	LOS A	0.1	1.6	0.30	0.61	0.30	48.8
North: Sandy Creek Road														
7	L2	15	80.0	16	80.0	0.059	6.5	LOS A	0.0	0.0	0.00	0.10	0.00	54.3
8	T1	71	30.0	75	30.0	0.059	0.0	LOS A	0.0	0.0	0.00	0.10	0.00	59.7
Approach		86	38.7	91	38.7	0.059	1.1	NA	0.0	0.0	0.00	0.10	0.00	58.6
All Vehicles		200	41.3	211	41.3	0.059	1.7	NA	0.1	1.6	0.05	0.13	0.05	57.5

Site Level of Service (LOS) Method: Delay (SIDRA). Site LOS Method is specified in the Parameter Settings dialog (Site tab).

Vehicle movement LOS values are based on average delay per movement.

Minor Road Approach LOS values are based on average delay for all vehicle movements.

NA: Intersection LOS and Major Road Approach LOS values are Not Applicable for two-way sign control since the average delay is not a good LOS measure due to zero delays associated with major road movements.

Delay Model: SIDRA Standard (Geometric Delay is included).

Queue Model: SIDRA Standard.

Gap-Acceptance Capacity: SIDRA Standard (Akçelik M3D).

HV (%) values are calculated for All Movement Classes of All Heavy Vehicle Model Designation.

# MOVEMENT SUMMARY

▼ Site: 2 [2034 Base AM Peak Hour (Site Folder: General)]

Beaudesert-Boonah Road / Sandy Creek Road Intersection

Site Category: Existing Design

Give-Way (Two-Way)

Vehicle Movement Performance														
Mov ID	Turn	INPUT VOLUMES		DEMAND FLOWS		Deg. Satn	Aver. Delay	Level of Service	95% BACK OF QUEUE		Prop. Que	Effective Stop Rate	Aver. No. Cycles	Aver. Speed
		[ Total veh/h ]	[ HV % ]	[ Total veh/h ]	[ HV % ]				[ Veh. veh ]	[ Dist m ]				
South: Sandy Creek Road														
1	L2	11	30.0	12	30.0	0.115	7.0	LOS A	0.4	3.9	0.49	0.71	0.49	49.6
3	R2	51	30.0	54	30.0	0.115	10.3	LOS B	0.4	3.9	0.49	0.71	0.49	49.4
Approach		62	30.0	65	30.0	0.115	9.7	LOS A	0.4	3.9	0.49	0.71	0.49	49.4
East: Beaudesert-Boonah Road														
4	L2	79	30.0	83	30.0	0.054	5.9	LOS A	0.0	0.0	0.00	0.57	0.00	52.3
5	T1	180	15.0	189	15.0	0.107	0.0	LOS A	0.0	0.0	0.00	0.00	0.00	59.9
Approach		259	19.6	273	19.6	0.107	1.8	NA	0.0	0.0	0.00	0.17	0.00	57.4
West: Beaudesert-Boonah Road														
11	T1	122	15.0	128	15.0	0.072	0.0	LOS A	0.0	0.0	0.00	0.00	0.00	60.0
12	R2	11	30.0	12	30.0	0.013	7.4	LOS A	0.0	0.4	0.39	0.60	0.39	50.7
Approach		133	16.2	140	16.2	0.072	0.6	NA	0.0	0.4	0.03	0.05	0.03	59.1
All Vehicles		454	20.0	478	20.0	0.115	2.5	NA	0.4	3.9	0.08	0.21	0.08	56.6

Site Level of Service (LOS) Method: Delay (SIDRA). Site LOS Method is specified in the Parameter Settings dialog (Site tab).

Vehicle movement LOS values are based on average delay per movement.

Minor Road Approach LOS values are based on average delay for all vehicle movements.

NA: Intersection LOS and Major Road Approach LOS values are Not Applicable for two-way sign control since the average delay is not a good LOS measure due to zero delays associated with major road movements.

Delay Model: SIDRA Standard (Geometric Delay is included).

Queue Model: SIDRA Standard.

Gap-Acceptance Capacity: SIDRA Standard (Akçelik M3D).

HV (%) values are calculated for All Movement Classes of All Heavy Vehicle Model Designation.

SIDRA INTERSECTION 9.0 | Copyright © 2000-2020 Akcelik and Associates Pty Ltd | sidrasolutions.com

Organisation: TRAFFIC AND TRANSPORT PLUS | Licence: PLUS / 1PC | Processed: Wednesday, 26 October 2022 4:49:34 PM

Project: F:\Jobs\TTPlus\10500\10551\Reports\20221000\_TIA\App C SIDRA\Beaudesert-Boonah Road\_Sandy Creek Road.sip9

# MOVEMENT SUMMARY

## Site: 2 [2034 Base PM Peak Hour (Site Folder: General)]

Beaudesert-Boonah Road / Sandy Creek Road Intersection

Site Category: Existing Design

Give-Way (Two-Way)

Vehicle Movement Performance														
Mov ID	Turn	INPUT VOLUMES		DEMAND FLOWS		Deg. Satn	Aver. Delay	Level of Service	95% BACK OF QUEUE		Prop. Que	Effective Stop Rate	Aver. No. Cycles	Aver. Speed
		[ Total veh/h ]	[ HV % ]	[ Total veh/h ]	[ HV % ]				[ Veh. veh ]	[ Dist m ]				
South: Sandy Creek Road														
1	L2	5	30.0	5	30.0	0.173	6.9	LOS A	0.7	5.8	0.57	0.81	0.57	48.1
3	R2	69	30.0	73	30.0	0.173	12.4	LOS B	0.7	5.8	0.57	0.81	0.57	47.9
Approach		74	30.0	78	30.0	0.173	12.0	LOS B	0.7	5.8	0.57	0.81	0.57	47.9
East: Beaudesert-Boonah Road														
4	L2	54	30.0	57	30.0	0.037	5.9	LOS A	0.0	0.0	0.00	0.57	0.00	52.4
5	T1	156	15.0	164	15.0	0.092	0.0	LOS A	0.0	0.0	0.00	0.00	0.00	60.0
Approach		210	18.9	221	18.9	0.092	1.5	NA	0.0	0.0	0.00	0.15	0.00	57.8
West: Beaudesert-Boonah Road														
11	T1	257	15.0	271	15.0	0.152	0.0	LOS A	0.0	0.0	0.00	0.00	0.00	59.9
12	R2	10	30.0	11	30.0	0.011	7.0	LOS A	0.0	0.4	0.35	0.58	0.35	50.9
Approach		267	15.6	281	15.6	0.152	0.3	NA	0.0	0.4	0.01	0.02	0.01	59.5
All Vehicles		551	18.8	580	18.8	0.173	2.3	NA	0.7	5.8	0.08	0.18	0.08	57.0

Site Level of Service (LOS) Method: Delay (SIDRA). Site LOS Method is specified in the Parameter Settings dialog (Site tab).

Vehicle movement LOS values are based on average delay per movement.

Minor Road Approach LOS values are based on average delay for all vehicle movements.

NA: Intersection LOS and Major Road Approach LOS values are Not Applicable for two-way sign control since the average delay is not a good LOS measure due to zero delays associated with major road movements.

Delay Model: SIDRA Standard (Geometric Delay is included).

Queue Model: SIDRA Standard.

Gap-Acceptance Capacity: SIDRA Standard (Akçelik M3D).

HV (%) values are calculated for All Movement Classes of All Heavy Vehicle Model Designation.

SIDRA INTERSECTION 9.0 | Copyright © 2000-2020 Akcelik and Associates Pty Ltd | sidrasolutions.com

Organisation: TRAFFIC AND TRANSPORT PLUS | Licence: PLUS / 1PC | Processed: Wednesday, 26 October 2022 4:49:59 PM

Project: F:\Jobs\TTPlus\10500\10551\Reports\20221000\_TIA\App C SIDRA\Beaudesert-Boonah Road\_Sandy Creek Road.sip9

# MOVEMENT SUMMARY

## Site: 2 [2034 Design AM Peak Hour (Site Folder: General)]

Beaudesert-Boonah Road / Sandy Creek Road Intersection

Site Category: Existing Design

Give-Way (Two-Way)

Vehicle Movement Performance														
Mov ID	Turn	INPUT VOLUMES		DEMAND FLOWS		Deg. Satn	Aver. Delay	Level of Service	95% BACK OF QUEUE		Prop. Que	Effective Stop Rate	Aver. No. Cycles	Aver. Speed
		[ Total veh/h ]	[ HV % ]	[ Total veh/h ]	[ HV % ]				[ Veh. veh ]	[ Dist m ]				
South: Sandy Creek Road														
1	L2	12	30.0	13	30.0	0.145	7.0	LOS A	0.6	4.9	0.51	0.74	0.51	49.4
3	R2	64	30.0	67	30.0	0.145	10.6	LOS B	0.6	4.9	0.51	0.74	0.51	49.2
Approach		76	30.0	80	30.0	0.145	10.0	LOS B	0.6	4.9	0.51	0.74	0.51	49.2
East: Beaudesert-Boonah Road														
4	L2	96	30.0	101	30.0	0.066	5.9	LOS A	0.0	0.0	0.00	0.57	0.00	52.3
5	T1	180	15.0	189	15.0	0.107	0.0	LOS A	0.0	0.0	0.00	0.00	0.00	59.9
Approach		276	20.2	291	20.2	0.107	2.1	NA	0.0	0.0	0.00	0.20	0.00	57.1
West: Beaudesert-Boonah Road														
11	T1	122	15.0	128	15.0	0.072	0.0	LOS A	0.0	0.0	0.00	0.00	0.00	60.0
12	R2	12	30.0	13	30.0	0.015	7.5	LOS A	0.1	0.5	0.41	0.61	0.41	50.6
Approach		134	16.3	141	16.3	0.072	0.7	NA	0.1	0.5	0.04	0.05	0.04	59.0
All Vehicles		486	20.7	512	20.7	0.145	2.9	NA	0.6	4.9	0.09	0.24	0.09	56.2

Site Level of Service (LOS) Method: Delay (SIDRA). Site LOS Method is specified in the Parameter Settings dialog (Site tab).

Vehicle movement LOS values are based on average delay per movement.

Minor Road Approach LOS values are based on average delay for all vehicle movements.

NA: Intersection LOS and Major Road Approach LOS values are Not Applicable for two-way sign control since the average delay is not a good LOS measure due to zero delays associated with major road movements.

Delay Model: SIDRA Standard (Geometric Delay is included).

Queue Model: SIDRA Standard.

Gap-Acceptance Capacity: SIDRA Standard (Akçelik M3D).

HV (%) values are calculated for All Movement Classes of All Heavy Vehicle Model Designation.

SIDRA INTERSECTION 9.0 | Copyright © 2000-2020 Akcelik and Associates Pty Ltd | sidrasolutions.com

Organisation: TRAFFIC AND TRANSPORT PLUS | Licence: PLUS / 1PC | Processed: Monday, 31 October 2022 3:14:47 PM

Project: F:\Jobs\TTPlus\10500\10551\Reports\20221000\_TIA\App C SIDRA\Beaudesert-Boonah Road\_Sandy Creek Road.sip9



# MOVEMENT SUMMARY

## Site: 2 [2034 Design PM Peak Hour (Site Folder: General)]

Beaudesert-Boonah Road / Sandy Creek Road Intersection

Site Category: Existing Design

Give-Way (Two-Way)

Vehicle Movement Performance														
Mov ID	Turn	INPUT VOLUMES		DEMAND FLOWS		Deg. Satn	Aver. Delay	Level of Service	95% BACK OF QUEUE		Prop. Que	Effective Stop Rate	Aver. No. Cycles	Aver. Speed
		[ Total veh/h ]	[ HV % ]	[ Total veh/h ]	[ HV % ]				[ Veh. veh ]	[ Dist m ]				
South: Sandy Creek Road														
1	L2	6	30.0	6	30.0	0.219	6.9	LOS A	0.8	7.5	0.59	0.82	0.59	47.9
3	R2	86	30.0	91	30.0	0.219	12.7	LOS B	0.8	7.5	0.59	0.82	0.59	47.7
Approach		92	30.0	97	30.0	0.219	12.4	LOS B	0.8	7.5	0.59	0.82	0.59	47.7
East: Beaudesert-Boonah Road														
4	L2	67	30.0	71	30.0	0.046	5.9	LOS A	0.0	0.0	0.00	0.57	0.00	52.4
5	T1	156	15.0	164	15.0	0.092	0.0	LOS A	0.0	0.0	0.00	0.00	0.00	60.0
Approach		223	19.5	235	19.5	0.092	1.8	NA	0.0	0.0	0.00	0.17	0.00	57.4
West: Beaudesert-Boonah Road														
11	T1	257	15.0	271	15.0	0.152	0.0	LOS A	0.0	0.0	0.00	0.00	0.00	59.9
12	R2	11	30.0	12	30.0	0.012	7.1	LOS A	0.0	0.4	0.36	0.59	0.36	50.9
Approach		268	15.6	282	15.6	0.152	0.3	NA	0.0	0.4	0.01	0.02	0.01	59.5
All Vehicles		583	19.4	614	19.4	0.219	2.8	NA	0.8	7.5	0.10	0.21	0.10	56.5

Site Level of Service (LOS) Method: Delay (SIDRA). Site LOS Method is specified in the Parameter Settings dialog (Site tab).

Vehicle movement LOS values are based on average delay per movement.

Minor Road Approach LOS values are based on average delay for all vehicle movements.

NA: Intersection LOS and Major Road Approach LOS values are Not Applicable for two-way sign control since the average delay is not a good LOS measure due to zero delays associated with major road movements.

Delay Model: SIDRA Standard (Geometric Delay is included).

Queue Model: SIDRA Standard.

Gap-Acceptance Capacity: SIDRA Standard (Akçelik M3D).

HV (%) values are calculated for All Movement Classes of All Heavy Vehicle Model Designation.

SIDRA INTERSECTION 9.0 | Copyright © 2000-2020 Akcelik and Associates Pty Ltd | sidrasolutions.com

Organisation: TRAFFIC AND TRANSPORT PLUS | Licence: PLUS / 1PC | Processed: Monday, 31 October 2022 3:15:08 PM

Project: F:\Jobs\TTPlus\10500\10551\Reports\20221000\_TIA\App C SIDRA\Beaudesert-Boonah Road\_Sandy Creek Road.sip9

# **Appendix D**

## **Results of Traffic Surveys**

# AUSTRAFFIC VIDEO INTERSECTION COUNT



**Site No.:** 1 **Weather:** Fine  
**Location:** Beaudesert Boonah Road/Sandy Creek Road, Bromelton  
**Day/Date:** Wednesday, 20 April 2022  
**Summary:** AM Peak : Hour ending - 9:00 AM  
 PM Peak : Hour ending - 4:00 PM

**Hour Ending:** PM Total Time  
**On-road classification:** Total Vehicles

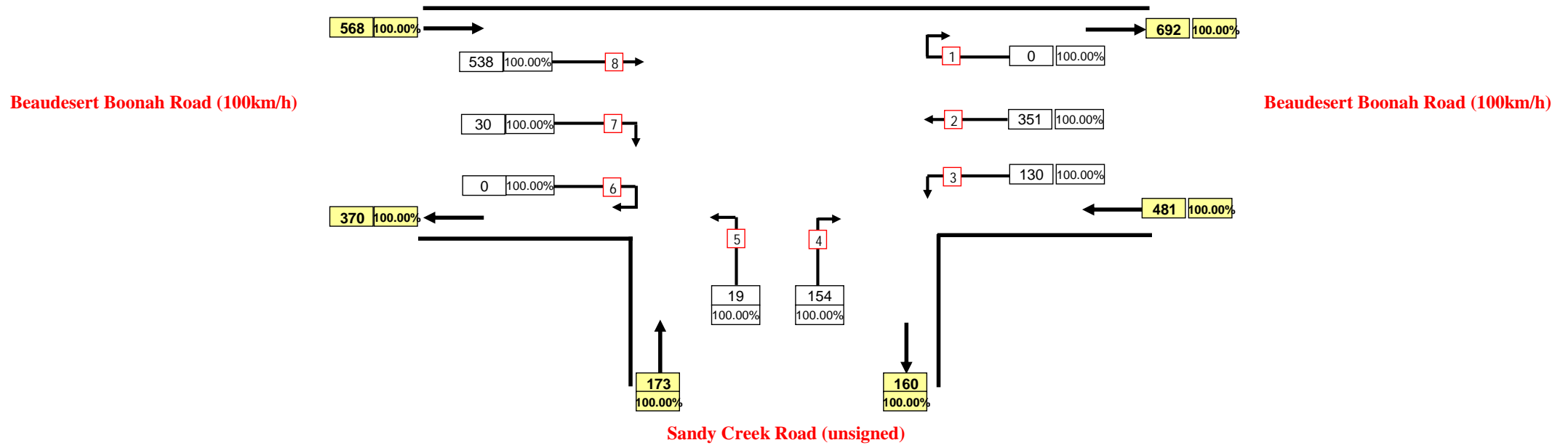

**Note:** 3.28% = proportion of selected vehicle classification as a percentage of total vehicles

AUSTRAFFIC VIDEO INTERSECTION COUNT

Site No.: 1 Weather: Fine  
 Location: Beaudesert Boonah Road/Sandy Creek Road, Bromelton  
 Day/Date: Wednesday, 20 April 2022  
 AM Peak: Hour ending - 9:00 AM  
 PM Peak: Hour ending - 4:00 PM

Beaudesert Boonah Road (100km/h)

Beaudesert Boonah Road (100km/h)

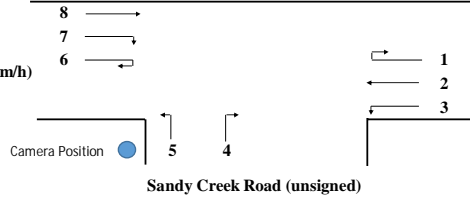

TIME (1/4 hr end)	Movement 1			Movement 2			Movement 3			Movement 4			Movement 5			Movement 6			Movement 7			Movement 8		
	Light Vehicles	Heavy Vehicles	Total	Light Vehicles	Heavy Vehicles	Total	Light Vehicles	Heavy Vehicles	Total	Light Vehicles	Heavy Vehicles	Total	Light Vehicles	Heavy Vehicles	Total	Light Vehicles	Heavy Vehicles	Total	Light Vehicles	Heavy Vehicles	Total	Light Vehicles	Heavy Vehicles	Total
6:45 AM	0	0	0	21	1	22	9	2	11	3	7	10	3	1	4	0	0	0	1	2	3	15	4	19
7:00 AM	0	0	0	20	8	28	16	4	20	5	1	6	0	2	2	0	0	0	1	1	2	11	4	15
7:15 AM	0	0	0	19	7	26	5	6	11	10	5	15	0	0	0	0	0	0	2	2	4	16	5	21
7:30 AM	0	0	0	20	0	20	7	1	8	3	4	7	2	1	3	0	0	0	1	0	1	20	5	25
7:45 AM	0	0	0	25	7	32	6	5	11	2	8	10	3	2	5	0	0	0	2	0	2	23	3	26
8:00 AM	0	0	0	22	2	24	7	1	8	5	4	9	2	1	3	0	0	0	0	1	1	21	8	29
8:15 AM	0	0	0	30	5	35	11	8	19	4	3	7	1	0	1	0	0	0	0	1	1	27	2	29
8:30 AM	0	0	0	20	3	23	8	8	16	2	4	6	3	0	3	0	0	0	2	1	3	29	3	32
8:45 AM	0	0	0	46	6	52	7	8	15	12	5	17	1	1	2	0	0	0	1	2	3	12	6	18
9:00 AM	0	0	0	28	4	32	6	6	12	3	7	10	1	2	3	0	0	0	1	1	2	13	4	17
9:15 AM	0	0	0	31	2	33	5	9	14	3	5	8	1	1	2	0	0	0	1	1	2	21	5	26
9:30 AM	0	0	0	32	2	34	5	4	9	1	7	8	1	1	2	0	0	0	1	1	2	18	4	22
3 hr Total	0	0	0	314	47	361	92	62	154	53	60	113	18	12	30	0	0	0	13	13	26	226	53	279
AM Peak	0	0	0	124	18	142	32	30	62	21	19	40	6	3	9	0	0	0	4	5	9	81	15	96

TIME (1/4 hr end)	Movement 1			Movement 2			Movement 3			Movement 4			Movement 5			Movement 6			Movement 7			Movement 8		
	Light Vehicles	Heavy Vehicles	Total	Light Vehicles	Heavy Vehicles	Total	Light Vehicles	Heavy Vehicles	Total	Light Vehicles	Heavy Vehicles	Total	Light Vehicles	Heavy Vehicles	Total	Light Vehicles	Heavy Vehicles	Total	Light Vehicles	Heavy Vehicles	Total	Light Vehicles	Heavy Vehicles	Total
2:45 PM	1	0	1	22	8	30	6	2	8	4	1	5	1	1	2	0	0	0	1	1	2	35	8	43
3:00 PM	0	0	0	20	9	29	6	1	7	7	2	9	0	0	0	0	0	0	5	0	5	36	7	43
3:15 PM	0	0	0	30	8	38	7	4	11	8	4	12	0	0	0	0	0	0	0	0	0	52	1	53
3:30 PM	0	0	0	26	3	29	6	5	11	8	2	10	0	1	1	0	0	0	1	0	1	36	8	44
3:45 PM	0	0	0	21	4	25	5	5	10	11	3	14	0	0	0	0	0	0	0	2	2	48	8	56
4:00 PM	0	0	0	31	0	31	8	2	10	13	6	19	2	1	3	0	0	0	2	3	5	39	11	50
4:15 PM	0	0	0	20	1	21	11	2	13	11	4	15	1	2	3	0	0	0	1	0	1	38	0	38
4:30 PM	0	0	0	20	2	22	8	5	13	7	1	8	1	2	3	0	0	0	5	0	5	35	4	39
4:45 PM	0	0	0	18	1	19	6	0	6	23	3	26	2	0	2	0	0	0	3	1	4	29	6	35
5:00 PM	0	0	0	24	1	25	6	2	8	5	3	8	0	1	1	0	0	0	0	1	1	20	6	26
5:15 PM	0	0	0	28	0	28	8	1	9	9	0	9	0	0	0	0	0	0	0	0	0	24	3	27
5:30 PM	0	0	0	16	2	18	5	1	6	3	0	3	0	1	1	0	0	0	2	1	3	27	6	33
5:45 PM	0	0	0	14	5	19	12	0	12	5	3	8	0	0	0	0	0	0	1	0	1	17	2	19
6:00 PM	0	0	0	14	3	17	3	3	6	7	1	8	3	0	3	0	0	0	0	0	0	31	1	32
3.5 hr Total	1	0	1	304	47	351	97	33	130	121	33	154	10	9	19	0	0	0	21	9	30	467	71	538
PM Peak	0	0	0	108	15	123	26	16	42	40	15	55	2	2	4	0	0	0	3	5	8	175	28	203

# AUSTRAFFIC VIDEO INTERSECTION COUNT

**Site No.:** 2 **Weather:** Fine  
**Location:** Bromelton quarry site access/Sandy Creek Road, Bromelton  
**Day/Date:** Wednesday, 20 April 2022  
**Summary:** AM Peak : Hour ending - 9:15 AM  
 PM Peak : Hour ending - 4:45 PM

**Hour Ending:** PM Total Time ▼  
**On-road classification:** Total Vehicles ▼



**Sandy Creek Road (100km/h)**

**Sandy Creek Road (100km/h)**

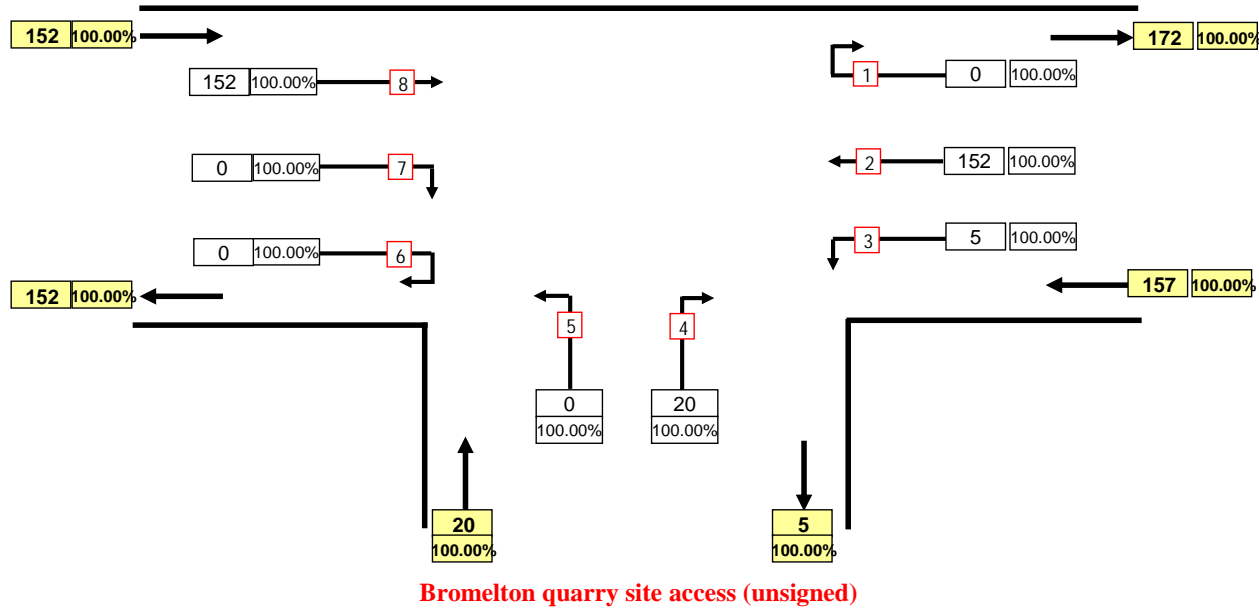

**Note:** 3.28% = proportion of selected vehicle classification as a percentage of total vehicles

AUSTRAFFIC VIDEO INTERSECTION COUNT

Site No.: 2 Weather: Fine  
 Location: Bromelton quarry site access/Sandy Creek Road, Bromelton  
 Day/Date: Wednesday, 20 April 2022  
 AM Peak: Hour ending - 9:15 AM  
 PM Peak: Hour ending - 4:45 PM

Sandy Creek Road (100km/h)

Sandy Creek Road (100km/h)

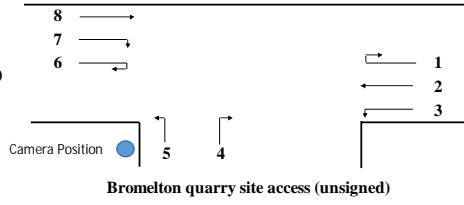

TIME (1/4 hr end)	Movement 1			Movement 2			Movement 3			Movement 4			Movement 5			Movement 6			Movement 7			Movement 8		
	Light Vehicles	Heavy Vehicles	Total	Light Vehicles	Heavy Vehicles	Total	Light Vehicles	Heavy Vehicles	Total	Light Vehicles	Heavy Vehicles	Total	Light Vehicles	Heavy Vehicles	Total	Light Vehicles	Heavy Vehicles	Total	Light Vehicles	Heavy Vehicles	Total	Light Vehicles	Heavy Vehicles	Total
6:45 AM	0	0	0	10	4	14	1	1	2	0	3	3	0	0	0	0	0	0	0	0	0	9	3	12
7:00 AM	0	0	0	15	4	19	1	3	4	1	1	2	0	0	0	0	0	0	0	1	1	2	3	5
7:15 AM	0	0	0	6	4	10	1	0	1	0	3	3	0	0	0	0	0	0	0	0	0	10	2	12
7:30 AM	0	0	0	7	4	11	0	2	2	0	1	1	0	0	0	0	0	0	0	0	0	6	4	10
7:45 AM	0	0	0	6	1	7	0	4	4	0	3	3	0	0	0	0	0	0	0	0	0	3	6	9
8:00 AM	0	0	0	7	2	9	0	0	0	1	2	3	0	0	0	0	0	0	0	0	0	6	3	9
8:15 AM	0	0	0	9	2	11	0	3	3	0	1	1	0	0	0	0	0	0	0	0	0	5	2	7
8:30 AM	0	0	0	11	8	19	0	5	5	0	2	2	0	0	0	0	0	0	0	0	0	6	1	7
8:45 AM	0	0	0	7	8	15	0	1	1	1	5	6	0	0	0	0	0	0	0	0	0	10	3	13
9:00 AM	0	0	0	6	2	8	2	5	7	0	2	2	0	0	0	0	0	0	0	0	0	5	6	11
9:15 AM	0	0	0	5	5	10	0	4	4	0	2	2	0	0	0	0	0	0	0	0	0	5	3	8
9:30 AM	0	0	0	4	5	9	0	1	1	0	5	5	0	0	0	0	0	0	1	0	1	3	6	9
3 hr Total	0	0	0	93	49	142	5	29	34	3	30	33	0	0	0	0	0	0	1	1	2	70	42	112
AM Peak	0	0	0	29	23	52	2	15	17	1	11	12	0	0	0	0	0	0	0	0	0	26	13	39

TIME (1/4 hr end)	Movement 1			Movement 2			Movement 3			Movement 4			Movement 5			Movement 6			Movement 7			Movement 8		
	Light Vehicles	Heavy Vehicles	Total	Light Vehicles	Heavy Vehicles	Total	Light Vehicles	Heavy Vehicles	Total	Light Vehicles	Heavy Vehicles	Total	Light Vehicles	Heavy Vehicles	Total	Light Vehicles	Heavy Vehicles	Total	Light Vehicles	Heavy Vehicles	Total	Light Vehicles	Heavy Vehicles	Total
2:45 PM	0	0	0	7	1	8	0	2	2	1	1	2	0	0	0	0	0	0	0	0	0	3	1	4
3:00 PM	0	0	0	11	1	12	0	0	0	2	1	3	0	0	0	0	0	0	0	0	0	5	1	6
3:15 PM	0	0	0	7	3	10	0	0	0	0	1	1	0	0	0	0	0	0	0	0	0	8	3	11
3:30 PM	0	0	0	5	4	9	1	0	1	1	1	2	0	0	0	0	0	0	0	0	0	8	3	11
3:45 PM	0	0	0	7	4	11	0	1	1	0	0	0	0	0	0	0	0	0	0	0	0	12	4	16
4:00 PM	0	0	0	8	7	15	0	0	0	0	0	0	0	0	0	0	0	0	0	0	0	15	6	21
4:15 PM	0	0	0	12	3	15	0	0	0	0	1	1	0	0	0	0	0	0	0	0	0	11	4	15
4:30 PM	0	0	0	13	3	16	0	0	0	0	0	0	0	0	0	0	0	0	0	0	0	9	5	14
4:45 PM	0	0	0	7	3	10	1	0	1	9	0	9	0	0	0	0	0	0	0	0	0	15	1	16
5:00 PM	0	0	0	6	2	8	0	0	0	2	0	2	0	0	0	0	0	0	0	0	0	3	4	7
5:15 PM	0	0	0	10	2	12	0	0	0	0	0	0	0	0	0	0	0	0	0	0	0	9	1	10
5:30 PM	0	0	0	5	2	7	0	0	0	0	0	0	0	0	0	0	0	0	0	0	0	2	0	2
5:45 PM	0	0	0	11	0	11	0	0	0	0	0	0	0	0	0	0	0	0	0	0	0	5	3	8
6:00 PM	0	0	0	5	3	8	0	0	0	0	0	0	0	0	0	0	0	0	0	0	0	9	2	11
3.5 hr Total	0	0	0	114	38	152	2	3	5	15	5	20	0	0	0	0	0	0	0	0	0	114	38	152
PM Peak	0	0	0	40	16	56	1	0	1	9	1	10	0	0	0	0	0	0	0	0	0	50	16	66

# AUSTRAFFIC VIDEO INTERSECTION COUNT

**Site No.:** 3 **Weather:** Fine

**Location:** Sandy Creek Road/Swan Gully Road, Bromelton

**Day/Date:** Wednesday, 20 April 2022

**Summary:** AM Peak : Hour ending - 9:15 AM

PM Peak : Hour ending - 4:45 PM

**Hour Ending:** PM Total Time

**On-road classification:** Total Vehicles

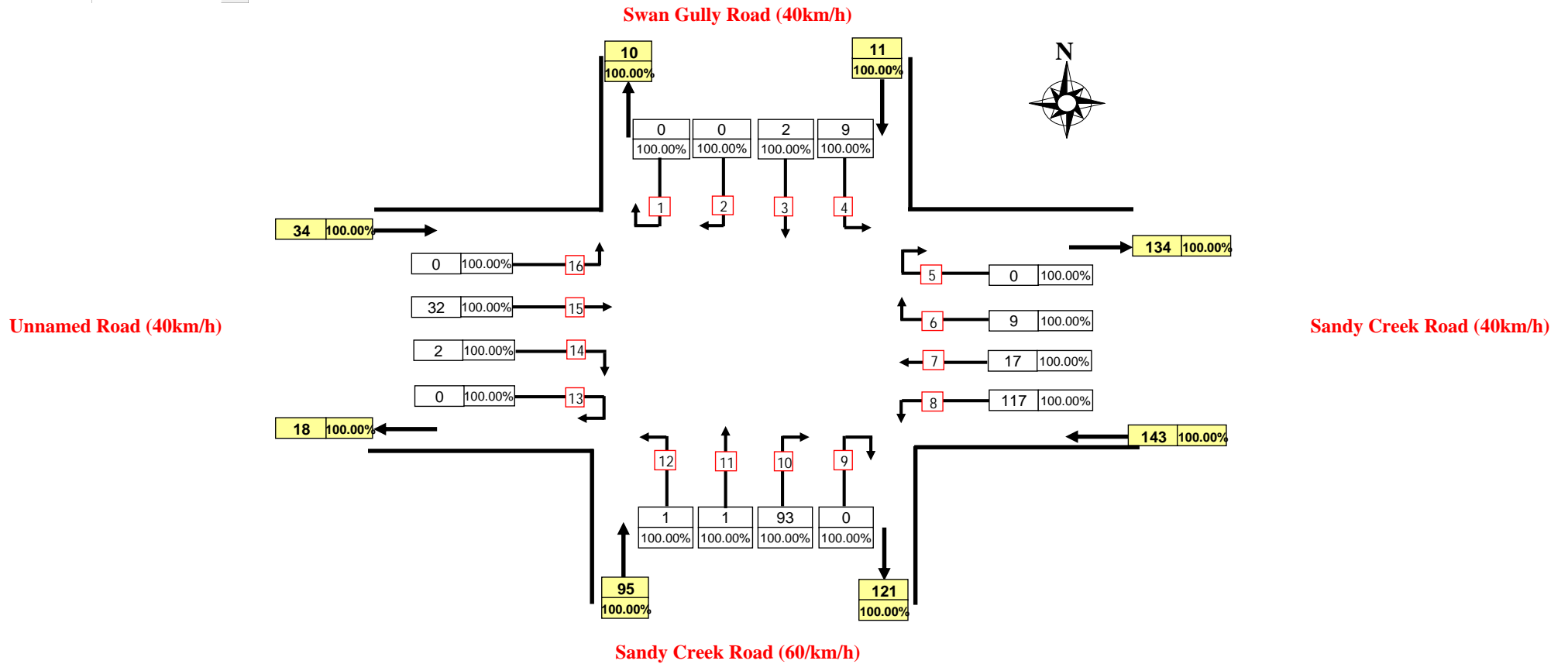

**Note:** 3.28% = proportion of selected vehicle classification as a percentage of total vehicles



**AUSTRAFFIC VIDEO INTERSECTION COUNT**

Site No.: 3 Weather: Fine  
 Location: Sandy Creek Road/Swan Gully Road, Bromelton  
 Day/Date: Wednesday, 20 April 2022  
 AM Peak: Hour ending - 9:15 AM  
 PM Peak: Hour ending - 4:45 PM

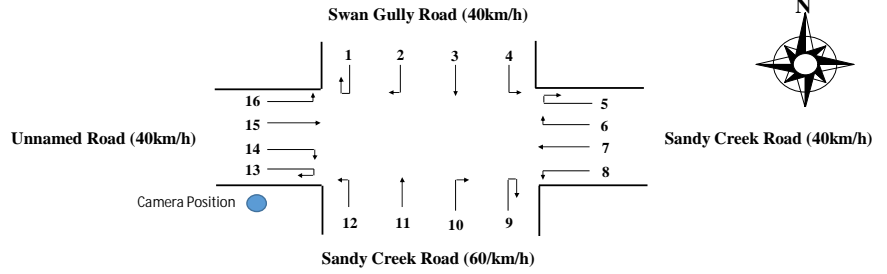

TIME (1/4 hr end)	Movement 1			Movement 2			Movement 3			Movement 4			Movement 5			Movement 6			Movement 7			Movement 8		
	Light Vehicles	Heavy Vehicles	Total	Light Vehicles	Heavy Vehicles	Total	Light Vehicles	Heavy Vehicles	Total	Light Vehicles	Heavy Vehicles	Total	Light Vehicles	Heavy Vehicles	Total	Light Vehicles	Heavy Vehicles	Total	Light Vehicles	Heavy Vehicles	Total	Light Vehicles	Heavy Vehicles	Total
6:45 AM	0	0	0	0	0	0	0	0	0	0	0	0	0	0	0	1	1	2	0	0	0	8	1	9
7:00 AM	0	0	0	0	0	0	0	0	0	1	1	0	0	0	0	1	0	1	2	3	5	12	1	13
7:15 AM	0	0	0	0	0	0	0	0	0	0	0	0	0	0	1	1	2	1	0	1	4	0	4	
7:30 AM	0	0	0	1	0	1	0	0	0	0	0	0	0	0	0	2	2	0	1	1	5	0	5	
7:45 AM	0	0	0	0	0	0	0	0	0	2	2	0	0	0	1	1	0	0	0	6	0	6		
8:00 AM	0	0	0	0	0	0	0	0	0	0	0	0	0	0	0	0	0	1	1	6	0	6		
8:15 AM	0	0	0	0	0	0	0	0	0	0	0	0	0	0	0	0	1	0	1	9	0	9		
8:30 AM	0	0	0	0	0	0	0	0	0	1	1	0	0	0	0	0	2	2	4	9	4	13		
8:45 AM	0	0	0	0	0	0	0	0	0	1	1	0	0	0	0	3	3	2	2	4	5	2	7	
9:00 AM	0	0	0	0	0	0	0	0	0	3	3	0	0	0	1	1	1	1	2	5	1	6		
9:15 AM	0	0	0	0	0	0	0	0	0	2	2	0	0	0	1	1	0	1	4	2	6			
9:30 AM	0	0	0	0	0	0	0	0	0	0	0	0	0	0	0	0	0	0	4	0	4			
<b>3 hr Total</b>	<b>0</b>	<b>0</b>	<b>0</b>	<b>1</b>	<b>0</b>	<b>1</b>	<b>0</b>	<b>0</b>	<b>0</b>	<b>10</b>	<b>10</b>	<b>0</b>	<b>0</b>	<b>0</b>	<b>2</b>	<b>10</b>	<b>12</b>	<b>11</b>	<b>11</b>	<b>22</b>	<b>77</b>	<b>11</b>	<b>88</b>	
<b>AM Peak</b>	<b>0</b>	<b>0</b>	<b>0</b>	<b>0</b>	<b>0</b>	<b>0</b>	<b>0</b>	<b>0</b>	<b>0</b>	<b>7</b>	<b>7</b>	<b>0</b>	<b>0</b>	<b>0</b>	<b>0</b>	<b>5</b>	<b>5</b>	<b>5</b>	<b>6</b>	<b>11</b>	<b>23</b>	<b>9</b>	<b>32</b>	

TIME (1/4 hr end)	Movement 1			Movement 2			Movement 3			Movement 4			Movement 5			Movement 6			Movement 7			Movement 8		
	Light Vehicles	Heavy Vehicles	Total	Light Vehicles	Heavy Vehicles	Total	Light Vehicles	Heavy Vehicles	Total	Light Vehicles	Heavy Vehicles	Total	Light Vehicles	Heavy Vehicles	Total	Light Vehicles	Heavy Vehicles	Total	Light Vehicles	Heavy Vehicles	Total	Light Vehicles	Heavy Vehicles	Total
2:45 PM	0	0	0	0	0	0	0	0	0	1	1	0	0	0	1	1	2	0	1	1	6	0	6	
3:00 PM	0	0	0	0	0	0	1	0	1	0	1	1	0	0	0	1	1	0	0	10	1	11		
3:15 PM	0	0	0	0	0	0	0	0	0	0	1	1	0	0	1	1	1	0	1	7	1	8		
3:30 PM	0	0	0	0	0	0	0	0	0	0	0	0	0	0	0	0	1	3	4	4	1	5		
3:45 PM	0	0	0	0	0	0	0	0	0	0	0	0	0	0	0	0	0	1	1	6	0	6		
4:00 PM	0	0	0	0	0	0	0	0	1	0	1	0	0	0	0	0	0	2	2	9	2	11		
4:15 PM	0	0	0	0	0	0	0	0	0	0	0	0	0	0	0	0	0	2	2	12	0	12		
4:30 PM	0	0	0	0	0	0	0	0	0	0	0	0	0	0	2	0	2	0	0	10	1	11		
4:45 PM	0	0	0	0	0	0	0	0	0	0	0	0	0	0	0	0	0	1	1	7	1	8		
5:00 PM	0	0	0	0	0	0	0	0	0	1	1	0	0	0	0	0	1	1	2	5	1	6		
5:15 PM	0	0	0	0	0	0	1	0	1	2	0	0	0	1	0	1	0	0	9	1	10			
5:30 PM	0	0	0	0	0	0	0	0	1	0	1	0	0	0	2	0	2	0	0	4	3	7		
5:45 PM	0	0	0	0	0	0	0	0	0	1	1	0	0	0	0	0	1	0	9	0	9			
6:00 PM	0	0	0	0	0	0	0	0	0	0	0	0	0	0	0	0	2	2	6	1	7			
<b>3.5 hr Total</b>	<b>0</b>	<b>0</b>	<b>0</b>	<b>0</b>	<b>0</b>	<b>0</b>	<b>2</b>	<b>0</b>	<b>2</b>	<b>4</b>	<b>5</b>	<b>9</b>	<b>0</b>	<b>0</b>	<b>0</b>	<b>6</b>	<b>3</b>	<b>9</b>	<b>4</b>	<b>13</b>	<b>17</b>	<b>104</b>	<b>13</b>	<b>117</b>
<b>PM Peak</b>	<b>0</b>	<b>0</b>	<b>0</b>	<b>0</b>	<b>0</b>	<b>0</b>	<b>0</b>	<b>0</b>	<b>1</b>	<b>0</b>	<b>1</b>	<b>0</b>	<b>0</b>	<b>0</b>	<b>2</b>	<b>0</b>	<b>2</b>	<b>0</b>	<b>5</b>	<b>5</b>	<b>38</b>	<b>4</b>	<b>42</b>	



# **Appendix E**

## **Results of Soil Testing on Sandy Creek Road**



Soil Surveys Engineering Pty Limited  
Specialists in Applied Geotechnics  
A.B.N. 70 054 043 631

[www.soilsurveys.com.au](http://www.soilsurveys.com.au)

**Directors & Associates**

NT Perkins BAppSc(AppGeol) BEng(Hons1) RPEQ  
GEJ Gray  
C Bailey BSc MSc FGS CGeol GMICE  
CP Johnson BEng(Civil) RPEQ  
N Brooking BE(Civil) MIEAust RPEQ  
G Burkitt BSc GCEnvMan MEngSc  
S Cottle  
**Consultant**  
PJ Dixon BE(Hons) RPEQ

Brisbane Office

Project No: 1-25720

Ref: 1-25720, 2022-11-17, LR VER 2

Author: Greg Gray/nb

30 November 2022

Traffic and Transport Plus

Email: [mmak@ttplus.com.au](mailto:mmak@ttplus.com.au)

**ATTENTION: MARGARET MAK**

**RE: GEOTECHNICAL INVESTIGATION  
PAVEMENT ASSESSMENT  
SANDY CREEK ROAD, BROMELTON**

## **1.0 INTRODUCTION**

### **1.1 General**

This report presents the results of the geotechnical investigation carried out by Soil Surveys Engineering Pty Limited (SSEng) for existing pavement assessment of Sandy Creek Road, Bromelton in accordance with SSEng's proposal dated 24<sup>th</sup> August 2022 (reference 1-25720, 2022-08-18, PR VER 3).

## **2.0 SITE INVESTIGATION**

### **2.1 Field Investigation**

Subsurface conditions were investigated by drilling and sampling eight boreholes, (BHA to BHD and BHA1 to BH D1, inclusive), to depths of 1.5m to 2.0m, using a 4WD mounted Jacro 105 drilling rig. Boreholes A, B, C and D were drilled through the existing roadway pavement formations, with probe boreholes, (designated A1, B1, C1 and D1), drilled in the road shoulder adjacent to the boreholes to obtain bulk samples of the subgrade for laboratory testing, as required by the client. The boreholes were cleared for underground services by a certified service locator prior to drilling. The field works were also controlled by a certified traffic controller subcontractor, due to authority requirements.

The soil classification descriptions and field tests were carried out in general accordance with the following Australian Standards:-

- AS 1726-1993 Geotechnical Site Investigations
- AS 1289 Methods of Testing Soils for Engineering Purposes

***Celebrating over  
45 years in  
Geotechnics***

Ph +617 3369 6000  
[info@soilsurveys.com.au](mailto:info@soilsurveys.com.au)

Brisbane, Level 1, 87 Schneider Road, Eagle Farm, QLD, 4009  
Gold Coast, Unit 8, 140 Millaroo Drive, Helensvale, QLD 4212



**NATA  
Accredited  
Laboratory**

Details of the investigation method, borehole records, dynamic cone penetrometer results and a site plan showing the location of the boreholes are attached.

The classification of soils in the field is subjective, based on the experience and judgement of the geotechnical driller and some variations in the soil description, from the actual material type may occur.

## 2.2 Subsurface Profile

The subsurface profile encountered consisted of the following:-

- Pavement formation comprising an asphalt wearing surface (10mm thick) over dense pavement gravel layers described as silty sandy gravels, ranging in thicknesses from:
  - Upper level 140mm to 290mm
  - Lower layer 150mm to 500mm
  - Total thickness 290mm to 690mm
- Fill material consisting of hard sandy clay, dense sand and medium dense clayey gravels. The dense sand fill in BHA extended to the termination depth of the borehole, at 1.5m.
- Natural high plasticity clays with varying sand and silt content extended beneath the fill to the termination depths of BH's B, C and D. The strength of the clays varied from firm to very stiff, with firm to stiff clay encountered in BHD between 0.6m and 1.3m depth.

Groundwater was not intersected in any of the boreholes at the time of investigation.

**TABLE 1 SUMMARY OF BOREHOLE INTERSECTIONS**

BH No.	Pavement Foundation			Fill Material (m)	Natural Clay (CH) (m)	Termination Depth (m)
	Asphalt (mm) Note <sup>(4)</sup>	Gravels (mm)				
		Upper Layer (mm)	Lower Layer (mm)			
A	10	190	500	0.70-TD	NE	1.50
B	10	290	200	0.50-0.60	0.60-TD	1.50
C	10	140	250	0.40-0.60	0.60-TD	1.50
D	10	140	450	NE	0.60-TD <sup>(5)</sup>	1.50
1. Depth in mm and metres, as noted above, below surface level at date of drilling 2. NE = Not Encountered 3. TD = Termination Depth 4. Approximate Asphalt Thicknesses 5. Firm to stiff zone encountered between 0.6m and 1.3m depths						

## 2.3 Laboratory Testing

Laboratory testing was carried out on a selected sample retrieved from the site investigation program and was directed towards assessing pavement subgrade parameters.

A summary of the laboratory test results is included in Table 2, with the test certificates attached at the end of this report.

**TABLE 2 SUMMARY OF LABORATORY TESTING**

Borehole No	Depth (m)	Classification	FMC (%)	OMC (%)	MDD (t/m <sup>3</sup> )	Swell (%)	CBR (%)
A	0.7-1.2	Silty CLAY	41.1	37.5	1.37	1.5	3.5
B	0.5-1.2	Sandy Gravelly CLAY	22.7	20.6	1.69	0.5	20
C	0.2-0.6	Sandy Gravelly CLAY	17.4	17.4	1.78	1.0	6
D	0.8-1.2	Sandy Gravelly CLAY	15.5	14.0	1.89	0.0	4.5

Notes:  
 FMC = Moisture Content of Sample Soil  
 OMC = Optimum Moisture Content  
 MDD = Maximum Dry Density  
 Swell = Percentage swell of CBR sample under 4.5kg surcharge and saturation  
 CBR = Soaked CBR (AS 1289 6.1.1)

### 3.0 ENGINEERING ASSESSMENT

#### 3.1 Trafficability and Site Preparation

At the time of the field investigation, trafficability was considered to be good due to the existing pavements.

However, problems may arise when the soil fabric, particularly the highly plastic clays, are disturbed with the removal of the existing pavement, vegetation, services and/or are or they become highly moist/wet. It should be noted that firm to stiff clay was encountered in the natural strata in BHD. Depressions could also be formed resulting in water traps with potential softening of adjacent and underlying soils.

The contractor should fully inform himself of the ground conditions on site prior to commencement of earthworks. This requirement should be explicit in any earthworks specifications or contract.

#### 3.2 Civil Works

##### Earthworks - General

Earthwork procedures should be carried out in a responsible manner in accordance with AS 3798-2007 'Guidelines on Earthworks for Commercial and Residential Developments'. It is recommended that the earthworks contractor make himself familiar with site conditions.

Earthwork procedures should include the following:-

- Clearing, stripping and grubbing should be carried out in areas subject to earthworks. Also all soils containing organic matter should be stripped from the construction areas. This material is not considered suitable for use as structural fill.
- Depressions formed by the removal of vegetation, underground elements etc. should have all disturbed weakened soil cleaned out and be backfilled with compacted select material.
- In areas where fill is to be placed, the existing ground surface should be proof rolled (if appropriate) using a vehicle with a tare of at least 5 tonnes. Areas demonstrating excessive movement should be treated (dried and recompacted) or removed and replaced with compacted fill. In areas of cut, proof rolling may be deferred until after the cut operation.

- Where fill is to be placed over sloping ground, e.g. embankments, the sloping ground/batters should be benched to 'key in' fill material and optimise compaction.
- The existing pavement gravels and fill, where free of organic and deleterious material, may be used for structural fill provided the moisture content of the soils, on placement, approximates the OMC (Optimum Moisture Content) appropriate for compaction. Consideration could be given to the reuse of the existing pavement gravels for use in future pavement formations, however without further testing it is not recommended that these gravels be reused other than as a CBR 15 material. Also, it would need to be ensured that these gravels are not contaminated with other materials
- The fill and natural clays could also be considered for use as embankment filling. However, it must be acknowledged that the clays are highly plastic and are expected to be particularly problematic for civil works (handling, conditioning and compaction).
- The existing fill and natural soils may require conditioning to dry out/wet up, otherwise difficulties could be experienced in handling and achieving adequate compaction.
- Imported select fill material, if required, should be a good quality select fill material with a soaked CBR >10% and a maximum aggregate size of 75mm.
- Fill should be compacted in layers (approximately 250mm loose thickness) to a density not less than 100% of maximum dry density in accordance with AS 1289 5.1.1 (Standard Compaction) and to the relevant authority specifications.
- Field density testing should be carried out in each fill lift placed to check the standard of compaction achieved and the placement moisture content. The frequency and extent of testing should be as per guidelines in AS 3798-2007, Section 8.0.
- The soils encountered on site (to borehole depths) should be within the excavation limits of a medium sized backhoe (e.g. Case 580 or similar) or small to medium sized excavator (10t-15t).
- Where fill is to be placed on sloping ground, particular care should be taken with respect to benching of the subgrade such that filling is carried out on a level, refer Section 2(i) and 2(j) of AS 3798-2007.

### Batters

A maximum batter angle of 26 degrees (2H:1V) may be adopted for fill batters less than 1m high. Fill batter slopes are dependent on suitable compaction being achieved.

It is essential that batters be suitably protected from erosion and scour by appropriate drainage and the establishment of ground cover and shrubs, etc. Imperative to the stability of the batters is good drainage to prevent potential fretting and/or slumping. It is therefore recommended that measures be taken to minimise the flow of water over batters.

Drying out of the reactive clays in the batters would result in surface cracks which have the potential to become saturated and fret during rainfall periods. This could result in eventual slumping and failure of these sections of the batter faces.



Consideration should therefore be given to protecting the final batter faces by cutting the slopes to a maintainable profile and providing a good surface covering, e.g. vegetation, grass.

### **3.3 Pavements**

#### **Design Values**

Laboratory testing of the fill and natural clay materials encountered in the investigation produced Soaked CBR values of 3.5% to 20%.

These values represented the subgrade strength available in the clay materials compacted to 100% standard density ratio and then subjected to saturation. This situation could occur in the long term if proper site drainage and maintenance procedures are not adopted.

Based on the above and providing that the recommendations outlined in the following section are complied with, preliminary pavement design values of CBR 3.5% may be adopted.

#### **Construction Considerations**

Along with recommendations contained in Sections 3.1 and 3.2, the following general earthworks recommendations are made:-

- i) Incorporate a perimeter drain at the pavement edges to prevent possible deterioration under wet weather.
- ii) Pavements should be well drained both during and upon completion of construction. Water should not be allowed to pond on or near pavement surfaces.
- iii) Pavement gravel should comply with the DOT quality specifications for sub base and base course material.
- iv) Subgrades should be compacted to achieve the minimum density ratios as outlined in Section 3.2 'Civil Works'.
- v) It is recommended that inspection and testing be carried out following general earthworks to confirm subgrade conditions.

## 4.0 LIMITATIONS

We have prepared this report for the use of **Traffic and Transport Plus**, for design purposes in accordance with generally accepted geotechnical engineering practices. No other warranty, expressed or implied, is made as to the professional advice included in this report. This report has not been prepared for use by parties other than **Traffic and Transport Plus**. It may not contain sufficient information for purposes of other parties or for other uses.

Your attention is drawn to the attachment, 'Notes Relating to this Report'. Interpretation of factual data given in this report is based on judgement, not a greater knowledge of facts other than those reported.

Interpretation of the information shown on the logs, and its application to design and construction, should therefore take into account the spacing of boreholes, the method of drilling, the frequency of sampling and testing and the possibility of other than "straight line" variations between the boreholes. Subsurface conditions between boreholes may vary significantly from conditions encountered at the borehole locations.

In the event that conditions encountered on site during construction appear to vary from those expected from the information contained in the report, the Company requests that it immediately be notified. Most problems are more readily resolved when conditions are exposed than at some later stage, after the event.

Soil Surveys Engineering consider that a documentation review service (during the design phase and prior to construction) to verify that the intent of geotechnical recommendations is properly reflected in the design, along with construction inspections, forms a very important component of the geotechnical engineering design service/process.

This statement is not intended to reduce the level of responsibility accepted by Soil Surveys Engineering in accordance with our commission, but rather to ensure that all parties who may rely on this report are aware of the responsibilities each assumes in doing so and the risks they accept should they decline to have Soil Surveys Engineering carry out a geotechnical documentation review and geotechnical construction inspections.

The geotechnical review ensures geotechnical risks to our Client and their project are minimised at the design and tender stage of the project. Further, with Soil Surveys Engineering being commissioned to carry out geotechnical construction inspections, an opportunity at the time of construction to confirm any assumptions made in the preparation of the report and allow the effect of any normally occurring variation in ground conditions to be assessed with respect to construction becomes available.

It is highly recommended that the Client avail themselves of these review and inspection services; our standard rates will apply.

Yours faithfully,



**G. GRAY**  
DIRECTOR

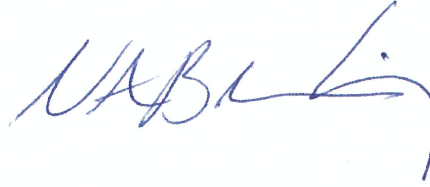

**N.A. BROOKING (RPEQ 19832)**  
ASSOCIATE – SENIOR GEOTECHNICAL ENGINEER

for and on behalf of  
**SOIL SURVEYS ENGINEERING PTY LIMITED**

Attachments:

- 1) Borehole Records and Dynamic Cone Penetrometer Results
- 2) Site Plan
- 3) Notes Relating to this Report



**Soil Surveys Engineering Pty. Limited**  
*Specialist in Applied Geotechnics*  
 PO Box 317, Paddington, 4064  
 +61 7 3369 6000  
 info@soilsurveys.com.au  
 www.soilsurveys.com.au

# BOREHOLE RECORD SHEET

**Location Number: BHA**  
 Project Number: 1-25720  
 Project Name: Pavement Investigation  
 Location: Sandy Creek Road, Bromelton  
 Client: Traffic Transport Plus  
 Date: 31/10/2022

Easting: 493625    Northing: 6903892    RL:  
 Logger: JCG    Operator: JCG    Machine: J 105

Drilling Method				Depth	Graphic	Description	DCP Test (blows/100mm)					Samples and Remarks				
TC	WB	RR	NW/LC				Casing	0	6	12	18		24	30		
					0.01	ASPHALT										
					0.20	FILL Silty Sandy GRAVEL (GM): Dense, fine to medium sized, dark grey, fine to coarse grained sand, moist										D
					0.70	FILL Silty Sandy GRAVEL (GM): Dense, fine to medium sized, light brown, fine to medium grained sand, moist										D
					1.50	FILL SAND (SP): Dense, fine to medium grained, light brown, trace low plasticity clay, trace fine sized gravel, moist										D
					1.50	BOREHOLE BHA TERMINATED AT 1.50 m										
					2.0											
					2.5											

SOIL SURVEYS 2.00.LIB.2017-07-13.GLB.Log.SOIL\_SURVEY\_AUGER\_LOG2\_1-25720.GINT.GPJ <<DrawingFile>> 29/11/2022 17:05 10.02.00.04 Developed by Dalgel

- Comments:**
1. Groundwater Not Encountered
  2. DCP refusal at 0.36m

**Weathering Grades**  
 RS - Residual Soil  
 XW - Extremely weathered  
 W - Highly weathered  
 MW - Moderately weathered  
 SW - Slightly weathered  
 FR - Fresh

**Rock Strength**  
 RS - Residual Soil  
 VL - Very low  
 L - Low  
 M - Medium  
 H - High  
 VH - Very high  
 EH - Extremely high

**Samples**

- USO
- SPT
- Disturbed Sample
- Bulk Sample
- Sample

Approved:  
 Date:

Water First Noted    Water Steady Level



**Soil Surveys Engineering Pty. Limited**  
 Specialist in Applied Geotechnics  
 PO Box 317, Paddington, 4064  
 +61 7 3369 6000  
 info@soilsurveys.com.au  
 www.soilsurveys.com.au

# BOREHOLE RECORD SHEET

**Location Number: BHA1**

Project Number: 1-25720

Project Name: Pavement Investigation

Location: Sandy Creek Road, Bromelton

Client: Traffic Transport Plus

Date: 31/10/2022

Page: 1 OF 1

Easting: 493627    Northing: 6903886    RL:  
 Logger: JCG    Operator: JCG    Machine: J 105

Drilling Method				Depth	Graphic	Description	DCP Test (blows/100mm)					Samples and Remarks	
TC	WB	RR	NW/LC				Casing	0	6	12	18		24
						FILL Silty Sandy GRAVEL (GM): Dense, fine to medium sized, light grey brown, fine to coarse grained sand, (trace organics )							D
						FILL Silty Sandy GRAVEL (GM): Dense, fine to medium sized, light brown, fine to medium grained sand, moist							D
						NATURAL Sandy CLAY (CH): Very stiff to hard, high plasticity, light brown mottled dark grey, fine to medium grained sand, w < pl							D
						Silty CLAY (CH): Stiff, high plasticity, dark grey, w > pl							B
						Silty CLAY (CH): Firm to stiff, high plasticity, dark grey, w > pl							
						BOREHOLE BHA1 TERMINATED AT 1.50 m							D

SOIL SURVEYS 2.00.LIB.2017-07-13.GLB.Log.SOIL\_SURVEY\_AUGER\_LOG2\_1-25720.GINT.GPJ <-DrawingFiles> 29/11/2022 17:05 10.02.00.04 Developed by Dalgel

**Comments:**  
 1. Groundwater Not Encountered  
 2. DCP refusal at 0.05m

**Weathering Grades**  
 RS - Residual Soil  
 XW - Extremely weathered  
 W - Highly weathered  
 MW - Moderately weathered  
 SW - Slightly weathered  
 FR - Fresh

**Rock Strength**  
 RS - Residual Soil  
 VL - Very low  
 L - Low  
 M - Medium  
 H - High  
 VH - Very high  
 EH - Extremely high

**Samples**  
 U50  
 SPT  
 Disturbed Sample  
 Bulk Sample

Approved:  
 Date:

Water First Noted    Water Steady Level



**Soil Surveys Engineering Pty. Limited**

Specialist in Applied Geotechnics

PO Box 317, Paddington, 4064  
+61 7 3369 6000  
info@soilsurveys.com.au  
www.soilsurveys.com.au

**BOREHOLE RECORD SHEET**

Location Number: BHB

Project Number: 1-25720

Project Name: Pavement Investigation

Location: Sandy Creek Road, Bromelton

Client: Traffic Transport Plus

Date: 31/10/2022

Page: 1 OF 1

Easting: 494292    Northing: 6904239    RL:  
Logger: JCG    Operator: JCG    Machine: J 105

Drilling Method				Depth	Graphic	Description	DCP Test (blows/100mm)					Samples and Remarks
TC	WB	RR	NM/LC				Casing	0	6	12	18	
					0.01	BITUMEN						
					0.30	FILL Silty Sandy GRAVEL (GM): Dense, fine to medium sized, dark grey brown, fine to coarse grained sand, moist					D	
					0.50	FILL Silty Sandy GRAVEL (GM): Medium dense, fine to coarse sized, light brown, fine to medium grained sand, moist					D	
					0.60	FILL Sandy CLAY (CL): Very stiff, low plasticity, dark grey and dark brown with light brown, fine to medium grained sand, trace fine to medium sized gravel, w < pl					D	
					1.0	NATURAL Sandy CLAY (CH): Very stiff, high plasticity, dark brown mottled light brown, fine to medium grained sand, w < pl					D	
					1.50	BOREHOLE BHB TERMINATED AT 1.50 m						
					2.0							
					2.5							

SOIL SURVEYS 2.00.LIB.2017-07-13.GLB.Log.SOIL\_SURVEY\_AUGER\_LOG2\_1-25720.GINT.GPJ <-DrawingFile> 29/11/2022 17:05 10.02.00.04 Developed by Dalgel

Comments:  
1. Groundwater Not Encountered

**Weathering Grades**  
RS - Residual Soil  
XW - Extremely weathered  
WV - Highly weathered  
OW - Distinctly weathered  
MW - Moderately weathered  
SW - Slightly weathered  
FR - Fresh

**Rock Strength**  
RS - Residual Soil  
VL - Very low  
L - Low  
M - Medium  
H - High  
VH - Very high  
EH - Extremely high

**Samples**  
U50  
SPT  
Disturbed Sample  
Bulk Sample

Approved:  
Date:

Water First Noted    Water Steady Level



**Soil Surveys Engineering Pty. Limited**  
 Specialist in Applied Geotechnics  
 PO Box 317, Paddington, 4064  
 +61 7 3369 6000  
 info@soilsurveys.com.au  
 www.soilsurveys.com.au

# BOREHOLE RECORD SHEET

**Location Number: BHB1**

Project Number: 1-25720

Project Name: Pavement Investigation

Location: Sandy Creek Road, Bromelton

Client: Traffic Transport Plus

Date: 31/10/2022

Page: 1 OF 1

Easting: 494290    Northing: 6904227    RL:  
 Logger: JCG    Operator: JCG    Machine: J 105

Drilling Method				Depth	Graphic	Description	DCP Test (blows/100mm)					Samples and Remarks	
TC	WB	RR	NW/LC				Casing	0	6	12	18		24
						FILL Silty SAND (SM): Loose to medium dense, fine to medium grained, dark brown, trace low plasticity clay, trace fine to medium sized gravel, moist (trace organics )							D
					0.30	FILL Sandy CLAY (CL): Low plasticity, dark brown mottled dark grey with light brown, fine to medium grained sand, trace fine to medium sized gravel, w < pl							D
					0.50	NATURAL Sandy CLAY (CH): Very stiff, high plasticity, dark brown mottled light brown, fine to medium grained sand, w < pl							D B
					1.0								
					1.5								
					1.50	BOREHOLE BHB1 TERMINATED AT 1.50 m							
					2.0								
					2.5								

Comments:  
 1. Groundwater Not Encountered

**Weathering Grades**  
 RS - Residual Soil  
 XW - Extremely weathered  
 WW - Highly weathered  
 OW - Distinctly weathered  
 MW - Moderately weathered  
 SW - Slightly weathered  
 FR - Fresh

**Rock Strength**  
 RS - Residual Soil  
 VL - Very low  
 L - Low  
 M - Medium  
 H - High  
 VH - Very high  
 EH - Extremely high

**Samples**  
 U50  
 SPT  
 Disturbed Sample  
 Bulk Sample

Approved:  
 Date:

SOIL SURVEYS 2.00 LIB 2017-07-13.GLB Log SOIL SURVEY AUGER LOG2 1-25720.GINT.GPJ <<DrawingFile>> 29/11/2022 17:06 10.02.00.04 Developed by Dalgel

Water First Noted    Water Steady Level





**Soil Surveys Engineering Pty. Limited**

Specialist in Applied Geotechnics

PO Box 317, Paddington, 4064

+61 7 3369 6000

info@soilsurveys.com.au

www.soilsurveys.com.au

**BOREHOLE RECORD SHEET**

**Location Number: BHC**

Project Number: 1-25720

Project Name: Pavement Investigation

Location: Sandy Creek Road, Bromelton

Client: Traffic Transport Plus

Date: 31/10/2022

Page: 1 OF 1

Easting: 495065    Northing: 6904445    RL:  
 Logger: JCG    Operator: JCG    Machine: J 105

Drilling Method				Depth	Graphic	Description	DCP Test (blows/100mm)					Samples and Remarks		
TC	WB	RR	NW/MLC				Casing	0	6	12	18		24	30
					0.01	ASPHALT								
					0.15	FILL Sandy GRAVEL (GP): Dense, fine to medium sized, dark grey, fine to coarse grained sand, moist								D
					0.40	FILL Silty Sandy GRAVEL (GM): Dense, fine to medium sized, dark grey brown, fine to coarse grained sand, moist								D
					0.50	FILL Clayey Sandy GRAVEL (GC): Medium dense, fine to coarse sized, dark grey light brown, fine to medium grained sand, low plasticity fines, moist								D
					0.60	NATURAL Sandy CLAY (CH): Stiff to very stiff, high plasticity, light brown, fine to medium grained sand, w ~ pl								
					1.50	BOREHOLE BHC TERMINATED AT 1.50 m								
					2.0									
					2.5									

SOIL SURVEYS 2.00.LIB.2017-07-13.GLB.Log.SOIL\_SURVEY\_AUGER\_LOG2\_1-25720.GINT.GPJ <-DrawingFiles> 29/11/2022 17:06 10.02.00.04 Developed by Dalgeel

Comments:  
 1. Groundwater Not Encountered

**Weathering Grades**  
 RS - Residual Soil  
 XW - Extremely weathered  
 W - Highly weathered  
 MW - Moderately weathered  
 SW - Slightly weathered  
 FR - Fresh

**Rock Strength**  
 RS - Residual Soil  
 VL - Very low  
 L - Low  
 M - Medium  
 H - High  
 VH - Very high  
 EH - Extremely high

**Samples**  
 U50  
 SPT  
 Disturbed Sample  
 Bulk Sample

Approved:  
 Date:

Water First Noted    Water Steady Level



**Soil Surveys Engineering Pty. Limited**  
 Specialist in Applied Geotechnics  
 PO Box 317, Paddington, 4064  
 +61 7 3369 6000  
 info@soilsurveys.com.au  
 www.soilsurveys.com.au

# BOREHOLE RECORD SHEET

**Location Number: BHC1**

Project Number: 1-25720

Project Name: Pavement Investigation

Location: Sandy Creek Road, Bromelton

Client: Traffic Transport Plus

Date: 31/10/2022

Page: 1 OF 1

Easting: 495064    Northing: 6904441    RL:  
 Logger: JCG    Operator: JCG    Machine: J 105

Drilling Method				Depth	Graphic	Description	DCP Test (blows/100mm)					Samples and Remarks	
TC	WB	RR	NW/LC				Casing	0	6	12	18		24
					0.20	FILL Silty SAND (SM): Medium dense, fine to medium grained, dark brown, trace fine to medium sized gravel, moist							D
					0.5	NATURAL Sandy CLAY (CH): Stiff to very stiff, high plasticity, light brown mottled light grey, fine to medium grained sand, w ~ pl							D B
					1.0								
					1.5								
					1.50	BOREHOLE BHC1 TERMINATED AT 1.50 m							
					2.0								
					2.5								

Comments:  
 1. Groundwater Not Encountered

**Weathering Grades**  
 RS - Residual Soil  
 XW - Extremely weathered  
 WW - Highly weathered  
 OW - Distinctly weathered  
 MW - Moderately weathered  
 SW - Slightly weathered  
 FR - Fresh

**Rock Strength**  
 RS - Residual Soil  
 VL - Very low  
 L - Low  
 M - Medium  
 H - High  
 VH - Very high  
 EH - Extremely high

**Samples**  
 U50  
 SPT  
 Disturbed Sample  
 Bulk Sample

Approved:  
 Date:

SOIL SURVEYS 2.00.LIB.2017-07-13.GLB.Log.SOIL\_SURVEY\_AUGER.LOG2.1-25720.GINT.GPJ.<<DrawingFiles>>.29/11/2022.17:06.10.02.00.04.Developed by Dalgel

Water First Noted    Water Steady Level



Soil Surveys Engineering Pty. Limited

Specialist in Applied Geotechnics

PO Box 317, Paddington, 4064

+61 7 3369 6000

info@soilsurveys.com.au

www.soilsurveys.com.au

BOREHOLE RECORD SHEET

Location Number: BHD

Project Number: 1-25720

Project Name: Pavement Investigation

Location: Sandy Creek Road, Bromelton

Client: Traffic Transport Plus

Date: 31/10/2022

Easting: 495821 Northing: 6904796 RL:
Logger: JCG Operator: JCG Machine: J 105

Table with columns: Drilling Method, Depth, Graphic, Description, DCP Test (blows/100mm), Samples and Remarks. Rows include ASPHALT, FILL Sandy GRAVEL (GW), FILL Silty SAND (SM), FILL Silty Sandy GRAVEL (GM), NATURAL Sandy CLAY (CH), and SANDY CLAY (CH).

SOIL SURVEYS 2.00 LIB 2017-07-13.GLB Log SOIL SURVEY AUGER LOG2 1-25720.GINT.GPJ <-DrawingFile>> 29/11/2022 17:06 10.02.00.04 Developed by Dalgel

Comments:
1. Groundwater Not Encountered

Weathering Grades
RS - Residual Soil
XX - Extremely weathered
XW - Highly weathered
OW - Distinctly weathered
MW - Moderately weathered
SW - Slightly weathered
FR - Fresh
Rock Strength
RS - Residual Soil
VL - Very low
L - Low
M - Medium
H - High
VH - Very high
EH - Extremely high

Samples
USO
SPT
Disturbed Sample
Bulk Sample
Approved:
Date:

Water First Noted Water Steady Level



# Soil Surveys Engineering Pty. Limited

Specialist in Applied Geotechnics

PO Box 317, Paddington, 4064

+61 7 3369 6000

info@soilsurveys.com.au

www.soilsurveys.com.au

# BOREHOLE RECORD SHEET

**Location Number: BHD1**

Project Number: 1-25720

Project Name: Pavement Investigation

Location: Sandy Creek Road, Bromelton

Client: Traffic Transport Plus

Date: 31/10/2022

Easting: 495820    Northing: 6904793    RL:  
 Logger: JCG    Operator: JCG    Machine: J 105

Drilling Method		Depth	Graphic	Description	DCP Test (blows/100mm)	Samples and Remarks	
TC	WB						RR
		0.10		FILL Silty Sandy GRAVEL (GM): Dense, fine to medium sized, dark grey brown, fine to coarse grained sand, moist (trace organics)		D	
		0.30		FILL Silty Sandy GRAVEL (GM): Dense, fine to medium sized, dark grey brown, fine to coarse grained sand, moist		D	
		0.5		FILL Silty Sandy GRAVEL (GM): Medium dense to dense, fine to medium sized, dark grey, fine to coarse grained sand, moist		D	
		0.80		NATURAL Sandy CLAY (CH): Stiff, high plasticity, dark brown mottled dark grey, fine to medium grained sand, w < pl		B	
		1.0					
		1.5					
		1.50		BOREHOLE BHD1 TERMINATED AT 1.50 m			
		2.0					
		2.5					
Comments: 1. Groundwater Not Encountered				Weathering Grades RS - Residual Soil XW - Extremely weathered W - Highly weathered MW - Moderately weathered SW - Slightly weathered FR - Fresh		Samples U50 SPT Disturbed Sample Bulk Sample	Approved: Date:
Water First Noted     Water Steady Level				Rock Strength RS - Residual Soil VL - Very low L - Low M - Medium H - High VH - Very high EH - Extremely high			

SOIL SURVEYS 2.00.LIB.2017-07-13.GLB.Log.SOIL\_SURVEY\_AUGER\_LOG2\_1-25720.GINT.GPJ.<-DrawingFiles>\_28/11/2022\_17:06\_10.02.00.04\_Developed by Dalgeel





SCALE  
NOT TO SCALE

A4	DRAWING NO. 1-25720-01	DATE 31/10/2022	CHECKED GG
----	---------------------------	--------------------	---------------

TITLE  
PAVEMENT INVESTIGATION  
BOREHOLE LOCATION PLAN

CLIENT  
TRAFFIC TRANSPORT PLUS  
LOCATION  
SANDY CREEK ROAD, BROMELTON



**SOIL SURVEYS**  
SOIL SURVEYS ENGINEERING PTY LIMITED  
CONSULTING GEOTECHNICAL ENGINEERS

# NOTES RELATING TO THIS REPORT

September, 2019

---

## **INTRODUCTION**

These notes are provided by Soil Surveys Engineering Pty Limited (the Company) to complement the geotechnical report in regard to classification methods and field procedures. Not all notes are necessarily relevant to all reports.

The ground is a product of continuing natural and man-made processes and therefore exhibits a variety of characteristics and properties which vary from place to place and can change with time. Geotechnical engineering involves gathering and assimilating limited information about these characteristics and properties in order to understand or predict the behaviour of the ground on a particular site under certain conditions. This report may contain such information obtained by inspection, excavation, probing, sampling, testing or other means of investigation. If so, they are directly relevant only to the ground at the place where and at the time when the investigation was carried out.

## **DESCRIPTION AND CLASSIFICATION METHODS**

**Soils** - The methods of description and classification of soils and rocks used in this report are based on Australian Standard 1726-2017 (Geotechnical Site Investigations), where appropriate. In general, descriptions cover the following properties - soil or rock type, colour, structure, strength or density, and inclusions. Identification and classification of soil and rock involves judgement and the Company infers accuracy only to the extent that is common in current geotechnical practice.

Soil types are described according to the dominant particle size and behaviour as set out in AS 1726-2017.

Cohesive soils are classified on the basis of strength (consistency) either by use of hand penetrometer, shear vane, laboratory testing or engineering examination. The strength terms are defined in AS 1726-2017 Table 11.

Non-cohesive soils are classified on the basis of relative density usually based on insitu testing or engineering examination (see AS 1726-2017 Table 12).

**Rocks** - Rock types are classified by their geological names (AS 1726-2017 Tables 15 to 18), together with descriptive terms regarding weathering (AS 1726-2017 Table 20), strength (AS 1726-2017 Table 19), defects (AS 1726-2017 Table 22), etc.

## **SAMPLING**

Sampling is carried out during drilling or from other excavations to allow engineering examination (and laboratory testing where required) of the soil or rock.

Disturbed samples taken during drilling provide information on plasticity, grain size, colour, moisture content, minor constituents and, depending upon sample disturbance, (information on strength and structure).

Undisturbed samples are taken by pushing a thin walled sample tube, usually 50mm diameter (U50), into the soil and withdrawing it with a sample of the soil contained in a relatively undisturbed state. Such samples yield information on structure and strength, and are necessary for laboratory

determination of shear strength, volume change potential and compressibility. Undisturbed sampling is generally effective only in cohesive soils.

Details of the type and method of sampling used are given on the attached logs.

## **SAMPLE STORAGE – SOIL, ROCK AND WATER**

### **SAMPLES**

Soil samples (not subject to testing) are not stored beyond a period of 90 days of taking or receiving said soil sample. Rock core (not subject to testing) is not stored beyond a period of six months of taking or receiving said rock core.

Should any party require that soil samples (not subject to testing) be stored beyond 90 days, or rock core (not subject to testing) be stored beyond six months, please contact Soil Surveys Engineering.

Water samples (not subject to testing) are not stored beyond a period of seven days of taking or receiving water samples.

### **TEST LOCATIONS**

Test locations (e.g. boreholes, CPT's, test pits etc.) were based on available access at the time of testing. Test locations may have been shifted if access was not suitable.

Unless noted otherwise, accuracy of test locations are to the accuracy of hand held GPS equipment.

### **INVESTIGATION METHODS**

The following is a brief summary of investigation methods currently adopted by the Company and some comments on their use and application.

**Test Pits** - These are normally excavated with a backhoe or a tracked excavator, allowing close examination of the insitu soils if it is safe to descend into the pit. The depth of penetration is limited to approximately 3.0m for a backhoe and up to 6.0m for an excavator. Limitations of test pits are the problems associated with disturbance and difficulty of reinstatement and the consequent effects on close-by structures. Care must be taken if construction is to be carried out near test pit locations to either properly recompact the backfill during construction or to design and construct the structure so as not to be adversely affected by poorly compacted backfill at the test pit location.

**Hand Auger Drilling** - A borehole of 50mm to 100mm diameter is advanced by manually operated equipment. Refusal of the augers can occur on a variety of materials such as hard clay, gravel or rock fragments and does not necessarily indicate rock level.

**Continuous Spiral Flight Augers** - The borehole is advanced using 75mm to 300 mm diameter continuous spiral flight augers, which are withdrawn at intervals to allow sampling or insitu testing. This is a relatively economical means of drilling in clays and in sands above the water table. Samples are returned to the surface by the flights or may be collected after withdrawal of the augers. Information from the drilling (as distinct from specific sampling) is of relatively lower reliability due to remoulding, inclusion of cuttings from above or softening of samples by groundwater, or



## NOTES RELATING TO THIS REPORT

September, 2019

uncertainties as to the original depth of the samples. Augering below the groundwater table has a lower reliability than augering above the water table. Various drill bits are attached to the base of the augers during the drilling. The depth of refusal of the different bit types can provide information as to the strength of the material encountered. Generally the 'TC' bit (a tungsten carbide tipped screw type bit) is used.

**Wash Boring** - The borehole is usually advanced by a rotary bit with water or fluid pumped down the hollow drill rods and returned up in the space between the rods and the soil or casing, carrying the drill cuttings. Only major changes in stratification can be determined from the cuttings, together with some information from "feel" and rate of penetration. More accurate information on soil strata is gained by regular testing and sampling using the Standard Penetration Test (SPT) and undisturbed thin walled tube samples (U50).

**Mud Stabilized Drilling** - Either Wash Boring or Continuous Core Drilling can use drilling mud as a circulating fluid to stabilize the borehole. The term "mud" encompasses a range of products ranging from bentonite to polymers such as Revert or Biogel. The mud tends to mask the cuttings and reliable identification is only possible from regular intact sampling (e.g. from SPT and U50 samples) or from rock coring, etc.

**Continuous Core Drilling** - A continuous core sample is obtained using a diamond or tungsten carbide tipped core barrel. Provided full core recovery is achieved (which is not always possible in very weak rocks and granular soils), this technique provides a very reliable method of investigation. In rocks, NMLC coring (nominal 52 mm diameter) is usually used with water flush. The length of core recovered is compared to the length drilled and any length not recovered is shown as CORE LOSS. The location of losses is determined on site by the supervisor. If the location of the loss is uncertain, it is placed at the top end of the run, when the core is placed in a storage tray and recorded on the log.

**Standard Penetration Tests** - Standard Penetration Tests (SPT) are used mainly in non-cohesive soils, but can also be used in cohesive soils, as a means of indicating density or strength. The test procedure is described in Australian Standard 1289, "Methods of Testing Soils for Engineering Purposes" - Test 6.3.1.

The test is carried out in a borehole by driving a 50mm diameter split sample tube with a tapered shoe, under the impact of a 63 kg hammer with a free fall of 760 mm. It is normal for the tube to be driven in three successive 150 mm increments and the 'N' value is taken as the number of blows for the last 300 mm, the upper 150 mm being neglected due to possible disturbance from the drilling method. In dense sands, very hard clays or weak rock, the full 450 mm penetration may not be practicable and the test is discontinued at a reduced penetration.

In the case where full penetration is obtained with successive blow counts for each 150 mm of, say 4, 6 and 7 blows, the record shows,

4, 6, 7

N = 13

In a case where the test is discontinued short of full penetration, say after 15 blows for the first 150 mm and 30 blows for the next 40 mm, the record shows:

15, 30/40mm

The results of the test can be related empirically to the engineering properties of the soil.

Occasionally, the drop hammer is used to drive 50mm diameter thin walled sample tubes (U50) in clays. In such circumstances, it is noted on the borehole logs.

A modification to the SPT test is where the same driving system is used with a solid 600 tipped steel cone of the same diameter as the SPT hollow sampler. The solid cone can be continuously driven for some distance in soft clays or loose sands, or may be used where damage would otherwise occur to the SPT. The results of this Solid SPT are shown as "N<sub>c</sub>" on the borehole logs, together with the number of blows per 150 mm penetration.

**Cone Penetration Tests** - Test Method - Cone Penetration Tests (CPT) are carried out in accordance with AS 1289 Test 6.5.1-1999, using an electrical friction-cone penetrometer.

The test essentially comprises the measurement of resistance to penetration of a cone of 35.7 mm diameter pushed into the soil at a rate of 10-20 mm per second by hydraulic force. The resistance to penetration is recorded in terms of pressure on the end area of the cone (cone resistance,  $q_c$ , in MPa) and friction on the side of the 135 mm long sleeve immediately above the top of the cone (friction resistance,  $f_s$ , in kPa). These forces are measured by electrical transducers (strain gauges) within the cone device. The ratio between friction resistance and cone resistance is also calculated as a percentage, i.e.-

$$\text{Friction Ratio (FR)} = \frac{\text{Friction Resistance, } f_s \text{ (kPa)} \times 100}{\text{cone resistance, } q_c \text{ (kPa)}}$$

The friction ratio, FR, is generally low in sands (less than 1% or 2%) and generally higher in clays (say 3% or more). The interpretation of sandy clays, clayey sands and material with a high silt content is more difficult, but intermediate values (between 1% and 3%) would be expected. Highly organic clays and peats generally have a friction ratio in excess of 5%.

Static cone data is recorded in the field on disc for later presentation using computer aided drafting.

The equipment can be operated from any conventional drill rig. A total applied load in the range of 4 to 10 tonnes is required for practical purposes, although lighter loads may be used. The cone penetrometers are available with various capacities of cone resistance ranging up to 100 MPa for general purpose investigations, while a range of 0 to 10 MPa can be used where more sensitive investigations of soft clay are required.

The cone resistance value provides a continuous measure of soil strength or density, and together with the friction ratio, provide very useful indications of the presence of narrow bands of geotechnically significant layers such as thin, soft clay layers or lenses of sand which might otherwise be missed using conventional drilling methods.

# NOTES RELATING TO THIS REPORT

September, 2019

---

The lithology of the encountered soils is interpreted from static cone data and is generally presented on the static cone log sheets.

It is important to note that the lithology is interpreted information and is based on research by Schmettmann (1970), Sanglerat (1972), Robinson and Campinalli (1986), modified to suit local conditions as indicated by borehole information and laboratory testing.

As soils generally change gradually it is sometimes difficult to accurately describe depths of strata changes, although greater accuracy is obtained with the static cone compared with conventional drilling. In addition, friction ratios decrease in accuracy with low cone resistance values, and in desiccated soils. As a result, some overlap and minor discrepancies may exist between static cone and nearby borehole information.

**Portable Dynamic Cone Penetrometers** - Portable Dynamic Cone Penetrometer (DCP) tests are carried out by driving a rod into the ground with a falling weight hammer and measuring the blows for successive 100mm increments of penetration.

The DCP comprises a Cone of 20 mm diameter with 30 degree taper attached to steel rods of smaller section.

The cone end is driven with a 9 kg hammer falling 510 mm (AS 1289 Test 6.3.2). The test was developed initially for pavement subgrade investigations, and empirical correlations of the test results with California Bearing Ratio have been published by various Road Authorities. The Company has developed their own correlations with Standard Penetration tests and Density Index tests in sands.

## **LOGS**

The borehole or test pit logs presented herein are an engineering and/or geological interpretation of the subsurface conditions, and their reliability will depend to some extent on the frequency of sampling and the method of drilling or excavation. Ideally, continuous undisturbed sampling or core drilling will enable the most reliable assessment but is not always practicable or possible to justify on economic grounds. In any case, the boreholes or test pits represent only a very small sample of the total subsurface conditions.

The attached explanatory notes define the terms and symbols used in preparation of the logs.

Interpretation of the information shown on the logs, and its application to design and construction, should therefore take into account the spacing of boreholes or test pits, the method of drilling or excavation, the frequency of sampling and testing and the possibility of other than "straight line" variations between the boreholes or test pits. Subsurface conditions between boreholes or test pits may vary significantly from conditions encountered at the borehole or test pit locations.

## **GROUNDWATER**

Where groundwater levels are measured in boreholes, there are several potential problems.

- Although groundwater may be present in lower permeability soils, it may enter the hole slowly or perhaps not at all during the time the hole is open.
- A localized perched water table may lead to an erroneous indication of the true water table.
- Water table levels will vary from time to time with seasons or recent weather changes and may not be the same at the time of construction.
- The use of water or mud as a drilling fluid will mask any groundwater inflow. Water has to be bailed out of the bore and mud must be washed out of the hole or "reverted" if water observations are to be made.

More reliable measurements can be made by use of standpipes which are read after stabilizing at periods ranging from several days to perhaps weeks for low permeability soils. Piezometers, sealed in a particular stratum, may be advisable in low permeability soils or where there may be interference from perched water tables or surface water.

## **FILL**

The presence of fill materials can often be determined only by the inclusion of foreign objects (e.g. bricks, steel, etc.) or by distinctly unusual colour, texture or fabric. Identification of the extent of fill materials will also depend on investigation methods and frequency. Where natural soils similar to those at the site are used for fill, it may be difficult with limited testing and sampling to reliably determine the extent of the fill.

The presence of fill materials is usually regarded with caution as the possible variation in density, strength and material type is much greater than with natural soil deposits. Consequently, there is an increased risk of adverse engineering characteristics or behaviour. If the volume and quality of fill is important to a project, then frequent test pit excavations are preferable to boreholes.

## **LABORATORY TESTING**

Laboratory testing is normally carried out in accordance with Australian Standard 1289 "Methods of Testing Soil for Engineering Purposes". Details of the test procedure used are given on the individual report forms and the attached explanatory notes summarize important aspects of the Laboratory Test Procedures adopted.

## **ENGINEERING REPORTS**

Engineering reports are prepared by qualified personnel and are based on the information obtained and on current engineering standards of interpretation and analysis. The information provided in Soil Surveys Engineering reports is opinion and interpretation and not factual. The client/contractor increases their risk by not retaining the person who authored the geotechnical report, to carry out site inspection and review (overseeing role) during construction, to confirm opinion and interpretation expressed in the report is accurate. Where the report has been prepared for a specific design proposal the information and interpretation may not be relevant if the design proposal is changed. If this happens, the Company will be pleased to



# NOTES RELATING TO THIS REPORT

September, 2019

---

review the report and the sufficiency of the investigation work.

Every care is taken with the report as it relates to interpretation of subsurface conditions, discussion of geotechnical aspects and recommendations or suggestions for design and construction. Since the test sites in any exploration represent a very small proportion of the total site and since the exploration only identifies actual ground conditions at the test sites, even under the best circumstances actual conditions may vary from those inferred to exist. No responsibility is taken for:-

- Unexpected variations in ground and/or groundwater conditions.
- Changes in policy or interpretation of policy by statutory authorities.
- The actions of other persons.
- Any work where the company is not given the opportunity to supervise the construction using the Companies designs/recommendations.

If differences occur, the Company will be pleased to assist with investigation or advice to resolve any problems occurring.

## **SITE ANOMALIES**

In the event that conditions encountered on site during construction appear to vary from those expected from the information contained in the report, the Company requests that it immediately be notified. Most problems are more readily resolved when conditions are exposed than at some later stage, well after the event.

Extreme events including but not limited to the results of climate change, e.g. flood levels above previously identified levels, beach scour or erosion beyond normal expectations (as identified by local authorities) extreme rainfall events, war, espionage, sabotage may result in different conditions between time of investigation and time of construction.

## **REPRODUCTION OF INFORMATION FOR**

### **CONTRACTUAL PURPOSES**

Attention is drawn to the document "Guidelines for the Provision of Geotechnical Information in Construction Contracts (1987)", published by the Institution of Engineers, Australia. Where information obtained from this investigation is provided for tendering purposes, it is recommended that all information, including the written report and discussion, be made available. In circumstances, where the discussion or comments section is not relevant to the contractual situation, it may be appropriate to prepare a specially edited document. The Company would be pleased to assist in this regard and/or to make additional report copies available for contract purposes at a nominal charge.

## **REVIEW OF DESIGN**

Where major civil or structural developments are propose or where only a limited investigation has been completed or where the geotechnical conditions/ constraints are quite

complex, it is prudent to have a joint design review which involves a senior geotechnical engineer. We would be happy to assist in this regard as an extension of our investigation commission. Construction drawings should be reviewed by Soil Surveys Engineering, with sufficient time to allow changes if required, prior to inspections. Otherwise Soil Surveys Engineering reserves the right to refuse to carry out inspections.

## **SITE INSPECTION**

The Company will always be pleased to provide engineering inspection services for geotechnical aspects of work to which this report is related.

- i. Site visits during construction to confirm reported ground conditions
- ii. Site visits to assist the contractor or other site personnel in identifying various soil/rock types such as appropriate footing or pier founding depths, the stability of a filled or excavated slope; or
- iii. Full-time engineering presence on site.

In the vast majority of cases it is advantageous to the principal for the geotechnical engineer who wrote the investigation report to be involved in the construction stage of the project.

The geotechnical engineer cannot take responsibility for variations in encountered conditions, where he is not given the opportunity to review plans for the proposed development with sufficient time to allow review and make changes to the proposed development if required, and where he is not given the opportunity to inspect the site and oversee construction methods with regard to site conditions with sufficient time to observe all relevant site conditions and operations.

## **RESPONSIBLE USE OF GEOTECHNICAL**

### **INFORMATION**

Recommendations in our report are for design purposes only and provided on the basis that inspections are carried out to allow finalisation of opinions and recommendations contained in our report.

The geotechnical investigation consisting of field and laboratory testing has been carried out to indicate typical conditions by indicating conditions and parameters at the specific locations of boreholes/test pits. Subsurface conditions are indicated at these locations only and the inference of conditions between or away from these locations (interpolation and extrapolation) involves a certain degree of risk. Persons inferring such conditions or carrying out such inferences should do so with a degree of caution and conservatism which is commensurate with the consequences of the risk of error.

Estimates of volumes based on our findings require interpolation and extrapolation between test locations and as such may be significantly different from actual volumes.

# **Appendix F**

## **Results of Pavement Contribution Assessment for Impacts on State-controlled Roads**

## Pavement Impact Assessment

Production Rate (tpa) = 800000

The methodology of the pavement impact assessment is based on Department of Transport and Main Roads' Guide to Traffic Impact Assessment Practice Note: Pavement Impact Assessment December 2018.

### Step 1: Project Parameters and Impact Potential Assessment Area

<b>Production Rate (tpa):</b>	800,000										
<b>First Operational Year:</b>	2024										
<b>Assessment Year (No of Years):</b>	10										
<b>Days of operation per year:</b>	300										
<b>Development Generated Tonnages (Year by Year)</b>											
	1	2	3	4	5	6	7	8	9	10	
	2024	2025	2026	2027	2028	2029	2030	2031	2032	2033	
% of "Base" Annual Tonnage	100%	100%	100%	100%	100%	100%	100%	100%	100%	100%	Total
Annual Tonnage	800,000	800,000	800,000	800,000	800,000	800,000	800,000	800,000	800,000	800,000	8,000,000

Class	Type	Payload	Unloaded SAR4	Loaded SAR4	Unloaded SAR5	Loaded SAR5	HV %	Weighted Average Payload	No Trip per day (In / Out)	Weighted Average Unloaded SAR4	Weighted Average loaded SAR4
3	Two axle truck	6.5	0.54	2.98	0.43	3.29	0%	0.0	0.0	0.000	0.000
4	Three axle truck	13.0	0.5	3.57	0.41	4.14	9%	1.2	7.0	0.045	0.321
5	Four axle truck	15.0	0.46	4.09	0.37	4.89	0%	0.0	0.0	0.000	0.000
6	Three axle articulated	11.5	0.6	4.43	0.46	4.88	0%	0.0	0.0	0.000	0.000
7	Four axle articulated	18.0	0.56	5.02	0.44	5.73	0%	0.0	0.0	0.000	0.000
8	Five axle articulated	24.5	0.52	5.61	0.41	6.58	0%	0.0	0.0	0.000	0.000
9	Six axle articulated (semi trailer)	26.5	0.51	4.93	0.41	5.61	0%	0.0	0.0	0.000	0.000
10	B-double	40.0	0.53	6.3	0.42	7.09	5%	2.0	3.9	0.027	0.315
11	Double road train (Road train 1)	51.5	0.55	8.34	0.43	9.53	0%	0.0	0.0	0.000	0.000
12	Triple road train	76.5	0.58	11.75	0.44	13.45	0%	0.0	0.0	0.000	0.000
'10' *	Truck and Dog	36.0	0.53	6.3	0.42	7.09	86%	31.0	67.2	0.456	5.418
<b>Total</b>	-	-	-	-	-	-	100%	34.1	78.1	0.53	6.05

\* According to Austroads Vehicle Classification System (duplicated as last page of this assessment), Truck and Dog is classified as Class 10.

**Contribution (cents / tonne):**

13.972

**Contribution (\$ / tonne)**

0.140





## Step 4: Calculate Development SAR4s

Production Rate (tpa) = 800000

Class	Type	Unloaded (Towards the Site)				Loaded (Away from the Site)			
		Daily Volumes	SAR4 per veh	SAR4 per day	SAR4 per year	Daily Volumes	SAR4 per veh	SAR4 per day	SAR4 per year
3	Two axle truck	0.0	0.54	0	0	0.0	2.98	0	0
4	Three axle truck (tadem truck)	7.0	0.5	4	1055	7.0	3.57	25	7531
5	Four axle truck	0.0	0.46	0	0	0.0	4.09	0	0
6	Three axle articulated	0.0	0.6	0	0	0.0	4.43	0	0
7	Four axle articulated	0.0	0.56	0	0	0.0	5.02	0	0
8	Five axle articulated	0.0	0.52	0	0	0.0	5.61	0	0
9	Six axle articulated (semi trailer)	0.0	0.51	0	0	0.0	4.93	0	0
10	B-double	3.9	0.53	2	621	3.9	6.3	25	7384
11	Double road train (Road train 1)	0.0	0.55	0	0	0.0	8.34	0	0
12	Triple road train	0.0	0.58	0	0	0.0	11.75	0	0
'10'	Truck and Dog	67.2	0.53	36	10684	67.2	6.3	423	126997
<b>Total</b>	-	-	-	41	12360	-	-	473	141912







**Step 7: Calculate Contribution to Offset Development Impacts (for Road Sections that Development SAR % > 5%)**

Production Rate (tpa) = 800000

**Towards the Quarry**

Sect. No	Road No	Road Name	Road Section	Carriage -way Code	Ch	Ch	Sealed Length	Marginal Cost (cents/SAR-km)	Dev. Trip %	No of Year (>5% increase in SAR)	Pavement Type	Fleet data (Year 1 to Year 10)				Development Contribution per year (Year 1 to Year 10) (\$)
												Average Production Rate for years > 5% increase in SAR	Average trips per year	Loaded SAR per Trip	SAR per year	
1	212	Beaudesert-Boonah Road	to the east	1	0.0	4.1	4.1	3.6	0.9	0	GN	0	0	6.1	0	0
2	212	Beaudesert-Boonah Road	to the west	1	4.1	31.6	27.5	4.4	0.1	0	GN	0	0	6.1	0	0
3	25A	Mount Lindesday Highway	to the north	1	41.9	40.4	1.5	3.8	0.9	0	AC/MC	0	0	6.1	0	0
4	25A	Mount Lindesday Highway	to the north	1	40.4	38.6	1.8	5.5	0.9	0	AC	0	0	6.1	0	0
5	25A	Mount Lindesday Highway	to the north	1	38.6	29.9	8.8	3.3	0.8	0	GN/AC	0	0	6.1	0	0
6	25A	Mount Lindesday Highway	to the north	1	29.9	19.0	10.9	3.6	0.8	0	GN/AC/CS	0	0	6.1	0	0
7	25A	Mount Lindesday Highway	to the north	1	19.0	8.4	10.6	3.0	0.7	0	GN/AC/CS	0	0	6.1	0	0
8	25B	Mount Lindesday Highway	to the south	1	0.0	1.5	1.5	3.3	0.0	0	GN/AC/CS	0	0	6.1	0	0
9	25B	Mount Lindesday Highway	to the south	1	1.5	31.2	29.7	6.7	0.0	0	GN/AC/CS	0	0	6.1	0	0

**Away from the Quarry**

Sect. No	Road No	Road Name	Road Section	Carriage -way Code	Ch	Ch	Sealed Length	Marginal Cost (cents/SAR-km)	Dev. Trip %	No of Year (>5% increase in SAR)	Pavement Type	Fleet data (Year 1 to Year 10)				Development Contribution per year (Year 1 to Year 10) (\$)
												Average Production Rate for years > 5% increase in SAR	Average trips per year	Loaded SAR per Trip	SAR per year	
1	212	Beaudesert-Boonah Road	to the east	1	0.0	4.1	4.1	3.58	90%	10	GN	800000	21096	6.1	127720	18747
2	212	Beaudesert-Boonah Road	to the west	1	4.1	31.6	27.5	4.36	10%	0	GN	0	0	6.1	0	0
3	25A	Mount Lindesday Highway	to the north	1	41.9	40.4	1.465	3.80	90%	10	AC/MC	800000	21096	6.1	127720	7110
4	25A	Mount Lindesday Highway	to the north	1	40.4	38.6	1.805	5.45	85%	10	AC	800000	19924	6.1	120625	11866
5	25A	Mount Lindesday Highway	to the north	1	38.6	29.9	8.77	3.27	80%	10	GN/AC	800000	18752	6.1	113529	32558
6	25A	Mount Lindesday Highway	to the north	1	29.9	19.0	10.86	3.59	75%	10	GN/AC/CS	800000	17580	6.1	106434	41496
7	25A	Mount Lindesday Highway	to the north	1	19.0	8.4	10.58	3.00	70%	0	GN/AC/CS	0	0	6.1	0	0
8	25B	Mount Lindesday Highway	to the south	1	0.0	1.5	1.51	3.31	0%	0	GN/AC/CS	0	0	6.1	0	0
9	25B	Mount Lindesday Highway	to the south	1	1.5	31.2	29.74	6.69	0%	0	GN/AC/CS	0	0	6.1	0	0

Average Production Rate (Year 1 to Year 10) (tpa):

800000
13.97
0.140

Contribution (cents / tonne)

Contribution (\$ / tonne)

Contribution per year (\$)

111777
--------