

Attachment 4

Site Plans

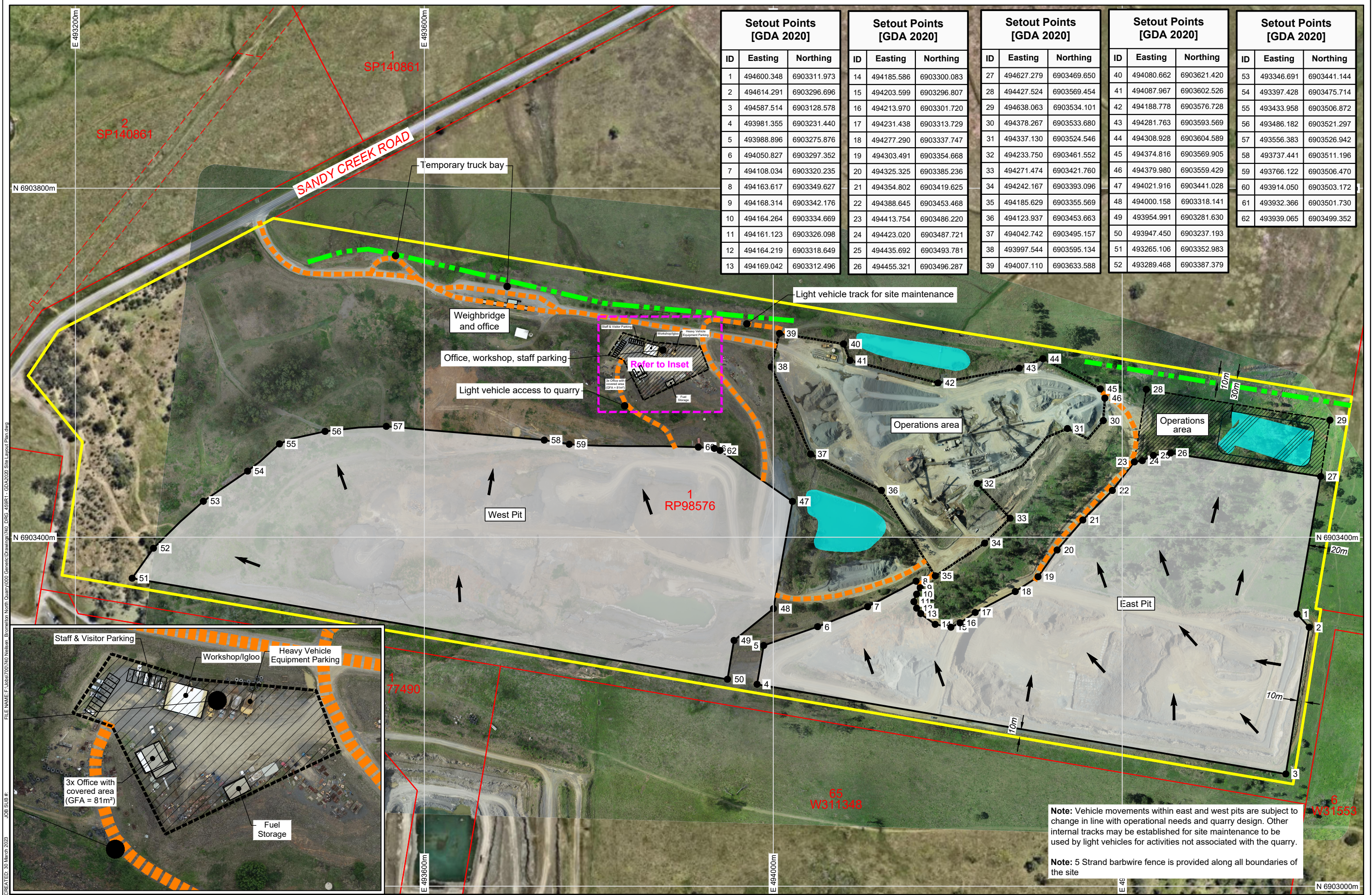

Setout Points [GDA 2020]			Setout Points [GDA 2020]			Setout Points [GDA 2020]			Setout Points [GDA 2020]			Setout Points [GDA 2020]		
ID	Easting	Northing	ID	Easting	Northing	ID	Easting	Northing	ID	Easting	Northing	ID	Easting	Northing
1	494600.348	6903311.973	14	494185.586	6903300.083	27	494627.279	6903469.650	40	494080.662	6903621.420	53	493346.691	6903441.144
2	494614.291	6903296.696	15	494203.599	6903296.807	28	494427.524	6903569.454	41	494087.967	6903602.526	54	493397.428	6903475.714
3	494587.514	6903128.578	16	494213.970	6903301.720	29	494638.063	6903534.101	42	494188.778	6903576.728	55	493433.958	6903506.872
4	493981.355	6903231.440	17	494231.438	6903313.729	30	494378.267	6903533.680	43	494281.763	6903593.569	56	493486.182	6903521.297
5	493988.896	6903275.876	18	494277.290	6903337.747	31	494337.130	6903524.546	44	494308.928	6903604.589	57	493556.383	6903526.942
6	494050.827	6903297.352	19	494303.491	6903354.668	32	494233.750	6903461.552	45	494374.816	6903569.905	58	493737.441	6903511.196
7	494108.034	6903320.235	20	494325.325	6903385.236	33	494271.474	6903421.760	46	494379.980	6903559.429	59	493766.122	6903506.470
8	494163.617	6903349.627	21	494354.802	6903419.625	34	494242.167	6903393.096	47	494021.916	6903441.028	60	493914.050	6903503.172
9	494168.314	6903342.176	22	494388.645	6903453.468	35	494185.629	6903355.569	48	494000.158	6903318.141	61	493932.366	6903501.730
10	494164.264	6903334.669	23	494413.754	6903486.220	36	494123.937	6903453.663	49	493954.991	6903281.630	62	493939.065	6903499.352
11	494161.123	6903326.098	24	494423.020	6903487.721	37	494042.742	6903495.157	50	493947.450	6903237.193			
12	494164.219	6903318.649	25	494435.692	6903493.781	38	493997.544	6903595.134	51	493265.106	6903352.983			
13	494169.042	6903312.496	26	494455.321	6903496.287	39	494007.110	6903633.588	52	493289.468	6903387.379			

FILE NAME: F:\Jobs\700740 Nelsens Bromelton North Quarry\020 Generic Drawings\440 DRG 459R1 - GDA2020 Site Layout Plan.dwg
 JOB SUB #
 CREATED: 30 March 2023

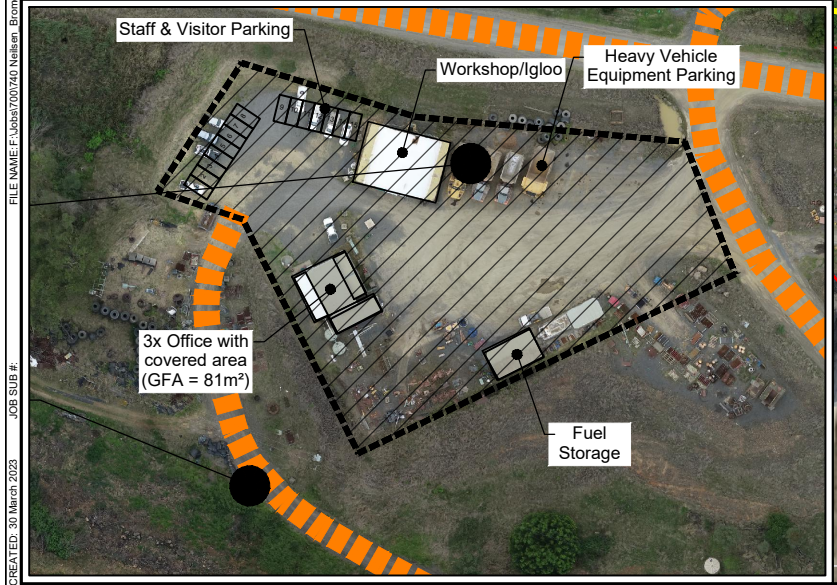

Note: Vehicle movements within east and west pits are subject to change in line with operational needs and quarry design. Other internal tracks may be established for site maintenance to be used by light vehicles for activities not associated with the quarry.

Note: 5 Strand barbwire fence is provided along all boundaries of the site

REV	DESCRIPTION	DATE	BY
1	Added Barbwire Fence and Tree plantations. Revised Changes	23-03-28	KJB

Data Sources:
 Photography: Groundwork Plus RPA Survey, Captured 2022-07-26
 Topography: Cadastral: © The State of Queensland (DNRME) 2022
 Ecosystem: Other: Background Photography: © The State of Queensland (DNRME) 2019
 THESE DESIGNS AND PLANS ARE COPYRIGHT AND ARE NOT TO BE USED OR REPRODUCED WHOLLY OR IN PART OR TO BE USED ON ANY PROJECT WITHOUT THE WRITTEN PERMISSION OF GROUNDWORK PLUS PTY LTD. ABN: 13 609 422 791

Legend:

- Site Boundary
- Cadastral Boundary
- Easement Boundary
- Extraction Footprint
- Water Storage / Sediment Basin
- Operations Area
- Internal Haul Road
- Direction of Extraction
- Vegetation Buffer

PROJECT: Bromelton North
 CLIENT: Neilsens Quality Gravels Pty Ltd

TITLE: Site Layout Plan

SCALE: 1:4,000
 DATE: 30 March 2023
 PRINTED: 31 March 2023

DRAWING NUMBER: 740.DRG.459
 REVISION: 1

DATUM: HORIZONTAL / VERTICAL / ZONE
 MGA / AHD / 56

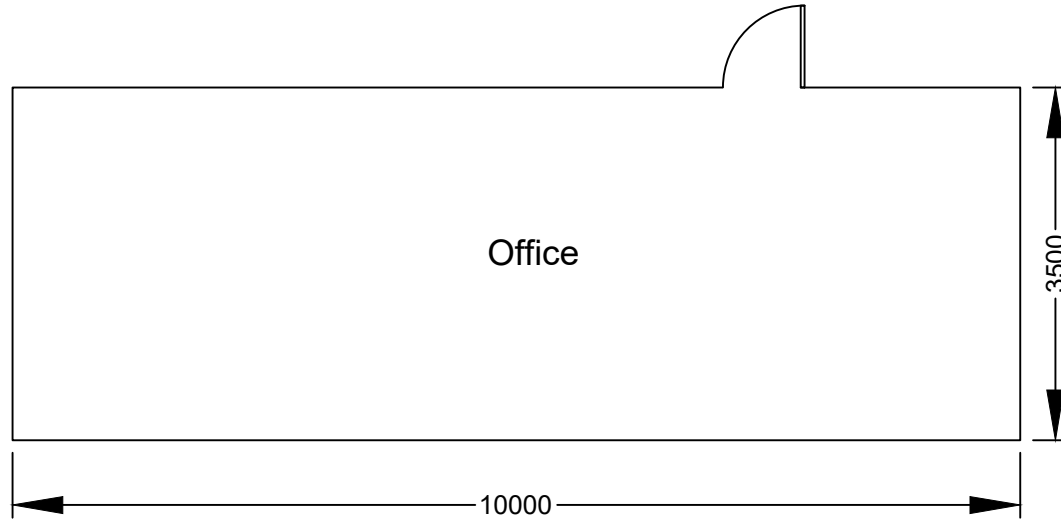

A - Site Office Floor Plan

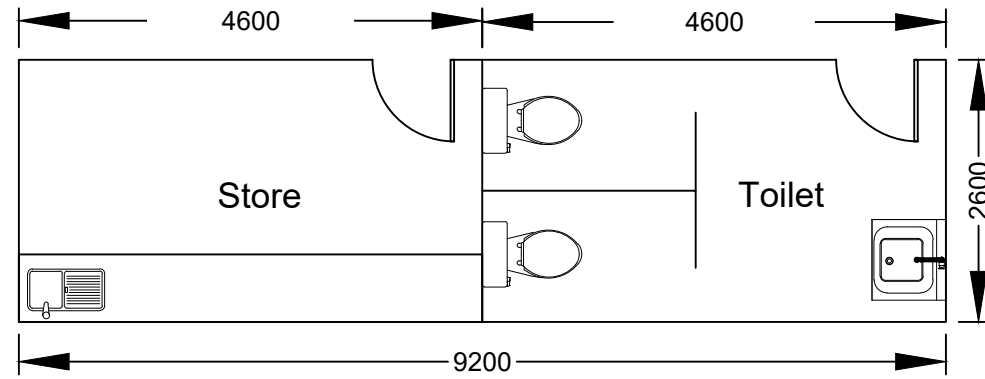

B - Storage/Toilet 1 Floor Plan

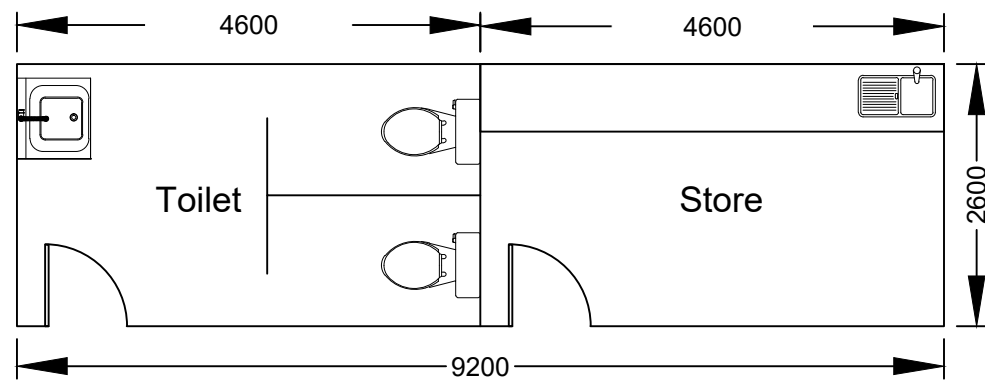

C - Storage/Toilet 2 Floor Plan

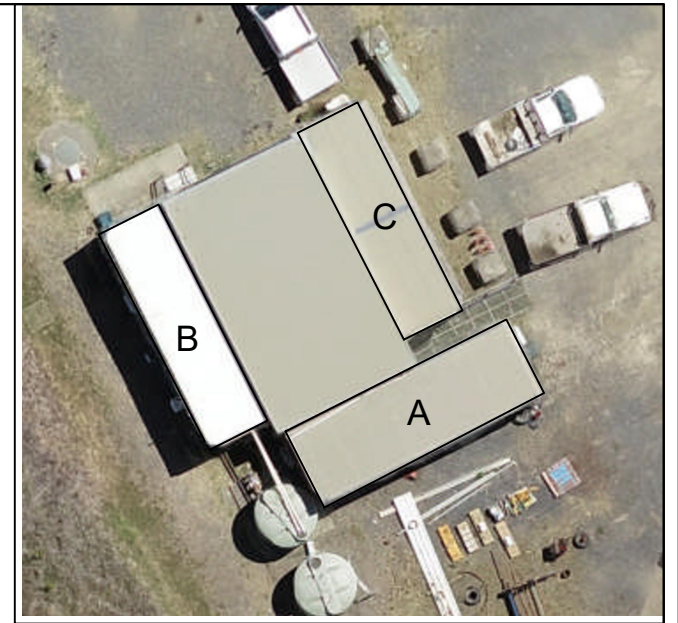

FILE NAME: F:\Jobs\700740 Neilsen - Bromelton North\000_Geomatic\Drawings\400_DRG_488_Site Buildings Floor Plans.dwg
 JOB SUB #
 CREATED: 31 March 2023

REV	DESCRIPTION	DATE	BY

Data Sources:
 Photography: Groundwork Plus RPA Survey, Captured 2023-02-27
 Topography: Cadastre
 Ecosystem: Other

THESE DESIGNS AND PLANS ARE COPYRIGHT AND ARE NOT TO BE USED OR REPRODUCED WHOLLY OR IN PART OR TO BE USED ON ANY PROJECT WITHOUT THE WRITTEN PERMISSION OF GROUNDWORK PLUS. ADM. 95 828 145 906

Legend:



PROJECT:	Bromelton North
CLIENT:	Neilsens Quality Gravels Pty Ltd

TITLE:		Site Buildings Floor Plans	
SCALE:	NTS 0	DRAWING NUMBER:	740.DRG.468
PH: +61 7 3871 0411	DATE: 31 March 2023	DRAWN: KJB	REVISION:
WWW.GROUNDWORK.COM.AU	PRINTED: 31 March 2023	CHECKED: MB	DATUM: HORIZONTAL / VERTICAL / ZONE
		GDA94 / MGA / AHD / 56	